

USER MANUAL

uFetti Shooter CA12/CA36

V1.1
2024/06/07

SHOWVEN[®]



SHOWVEN Technologies Co., Ltd

PREMIUM FACTORY - OFFICIAL DISTRIBUTOR
info@premiumfactory.eu | www.premiumfactory.eu

Thanks for choosing SHOWVEN uFetti Shooter, we wish it will bring you lots of exciting moments.

Please read the following user's manual carefully before operating this product.

▲ Safety Instructions

1. Safety icons explanation

Safety instructions warn of hazards when handling equipment and provide information on how to avoid those hazards. They are classified according to the severity of the hazard and are divided into the following groups. Please do follow all safety instructions in this document!

DANGER: Indicates a hazardous situation that, if not avoided, will result in death or serious injury. (This signal word is limited to the most extreme situations)

WARNING: Indicates a hazardous situation that, if not avoided, could result in serious injury

CAUTION: Indicates a hazardous situation that, if not avoided, could result in minor or moderate injury.

NOTICE: Provide additional or supplementary information.

2. General Safety Instructions

- ∨ Unauthorized repair are prohibited, it may cause serious incident.
- ∨ Make sure power supply in consistent with the rated voltage of the equipment, and the socket must well grounded. Unplug and turn off the machine when not use.
- ∨ Please pay attention to the use environment and safety distance, check this manual for details.
- ∨ After turning on the device, no person allows to stay in the danger area. Ensure all persons that are part of the show be informed about the safety distance, risks and functions of the device.
- ∨ Always have a CO₂ fire extinguisher and an extinguishing blanket in case of needed.
- ∨ If there be any doubt as to the safety operation of the device, the device should be taken out of service immediately. Check the power switch, cable connections and power plug carefully. If you can't solve it, please always contact SHOWVEN (info@showven.cn) for help.
- ∨ Use only SHOWVEN original confetti, otherwise, may leads to failure or danger.
- ∨ The operator responsible for the control of uFetti Shooter must always have a clear view of the device, so that he/she can stop the show immediately when there is danger. The main AC power switch should near operator. So that operator can turn off the power of all devices in case of abnormal.
- ∨ The device shall not be altered and applied to other use purpose.

3. Disclaimers:

SHOWVEN technologies Co., Ltd excludes liability for unsafe situations, accidents and damages resulting from:

1. Ignoring warnings or regulations as shown on product manual or this manual.
2. Use for other applications or circumstances other than those indicated herein.
3. Changes to the device, including use of non-original spare parts, lack of maintenance etc.
4. Dismantling device without authorization from SHOWVEN.
5. Use this machine by unqualified or untrained personnel.
6. Improper use of machine.

▲ Technical Specifications

uFetti Shooter is a type of new confetti/streamer shooter working with compressed air, equipped with built-in air compressor and battery (CA12) makes it super easier for stadium applications, together with SHOWVEN PyroSlave series firing system to achieve non interference wireless control, no DMX or power cable are needed. For faster pressurize of the tank, we reserve the external air coupling connector so that operator can use their own air compressor to fill the tank. To meet different output volume request, we developed two models uFetti Shooter CA12 and CA36 with different output capacity.

▲ Features

- \\ Upto 43m (CA12) / 45m (CA36) streamers output with full loading
- \\ PED certified tank
- \\ 2.5inch (CA12) / 3inch (CA36) valve, powerful output
- \\ Built-in air compressor with external air coupling connector available
- \\ True wireless, 18650 battery powered system (CA12)
- \\ Durable stainless steel tank, launch pipe and connectors
- \\ Multi safety configurations: cascable power cut-off E-stop connector, ARM indicator light, safety switch etc.
- \\ Touch screen
- \\ 3-PIN, 5-PIN DMX and 24V pyro signal port
- \\ Adjustable pressure upto 8bar
- \\ Digital and mechanical pressure display
- \\ 5L (CA12) / 10L (CA36) large capacity stainless steel launch pipe with self locking coupler

▲ Technical Specifications (CA12)

- \\ **Model:** uFetti Shooter CA12
- \\ **Dimension:** 600×560×880mm (with casters)
- \\ **Weight:** 88kg
- \\ **Input:** AC100-120V / AC200-240V, 50/60Hz
- \\ **Work Power:** 180W
- \\ **Interface:** Color touch screen
- \\ **ARM Indicator Light:** Yes
- \\ **Control:** DMX , DC24V signal
- \\ **DMX:** 3-pin and 5-pin DMX IN / OUT, 5-pin DMX IN support DC5V power supply for DMX receiver
- \\ **E-STOP Interface:** Yes, can be connected in series with E-stopper (optional)
- \\ **Output Direction:** -27°~41° (12 adjustable angles)
- \\ **Max. Output Distance:** 43m (20m Streamers), 22m (confetti)
- \\ **Pressure Rebuilt Time:** Appr.5min to 8bar
- \\ **Battery Powered Design:** Yes, 16pcs 18650 cells (customer prepare it locally)
- \\ **Rechargeable Times with Fully Charged Battery:** appr. 2-3times, depends on target pressure
- \\ **Maximum Pressure:** 8bar (116psi)
- \\ **Output Pipe Volume Capacity:** 5L (2kg paper confetti; 3kg metallic confetti)

- \ **Pressure Tank Volume:** 12L
- \ **External Air Compressor Connector:** Yes
- \ **Caster:** 4 casters with brake

▲ **Technical Specifications (CA36)**

- \ **Model:** uFetti Shooter CA36
- \ **Dimension:** 730×645×880mm (with casters)
- \ **Weight:** 121kg
- \ **Input:** AC100-240V, 50/60Hz
- \ **Work Power:** 220W
- \ **Interface:** Color touch screen
- \ **ARM Indicator Light:** Yes
- \ **Control:** DMX , DC24V signal
- \ **DMX:** 3-pin and 5-pin DMX IN / OUT, 5-pin DMX IN support DC5V power supply for DMX receiver
- \ **E-STOP Interface:** Yes, can be connected in series with E-stopper (optional)
- \ **Output Direction:** -27°~41° (12 adjustable angles)
- \ **Max. Output Distance:** 45m (20m Streamers), 22m (confetti)
- \ **Pressure Rebuilt Time:** Appr.8min to 8bar
- \ **Battery Powered Design:** No
- \ **Maximum Pressure:** 8bar (116psi)
- \ **Output Pipe Volume Capacity:** 10L (4kg paper confetti; 6kg metallic confetti)
- \ **Pressure Tank Volume:** 36L
- \ **External Air Compressor Connector:** Yes
- \ **Caster:** 4 casters with brake

▲ Structure

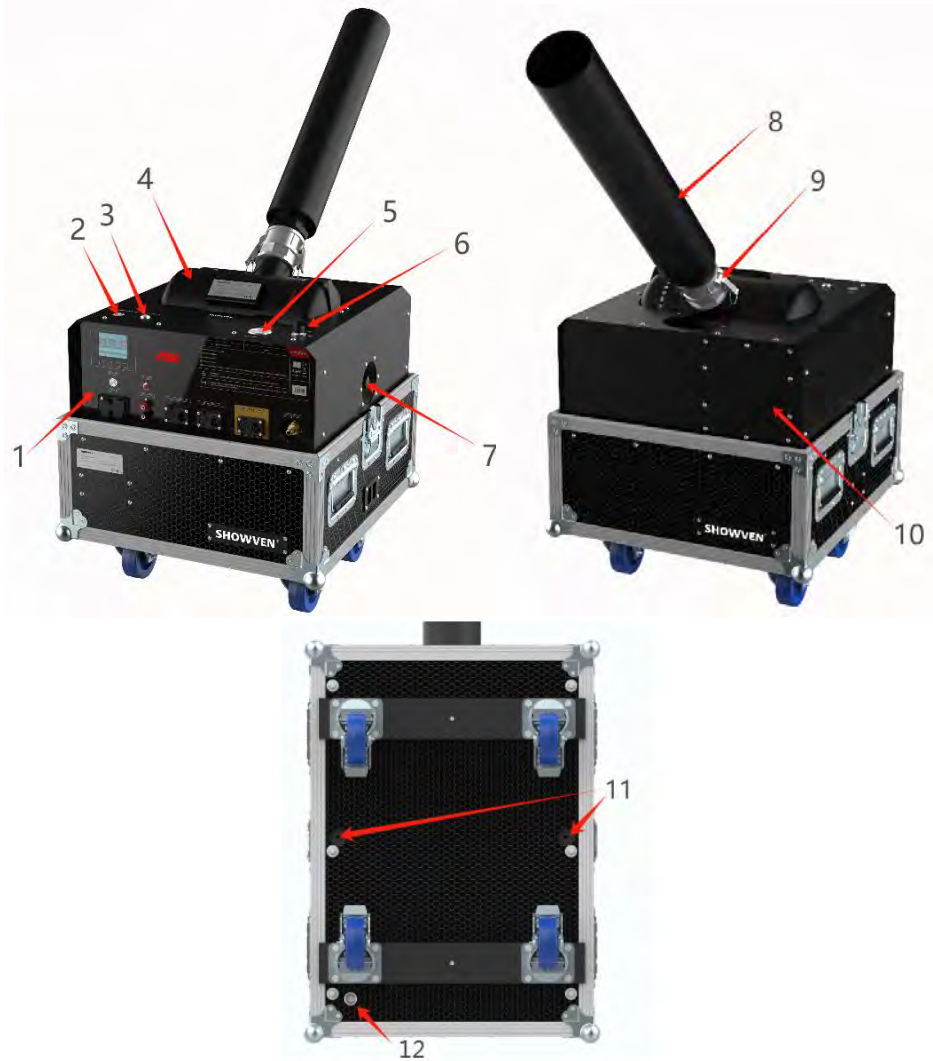

- | | |
|--------------------------------|-------------------------------|
| 1. Control Panel | 7. Angel Plunger |
| 2. Air Compressor Power Switch | 8. Output Pipe |
| 3. Safety Key | 9. Self-Locking Quick Coupler |
| 4. PED Certified Tank | 10. Battery Box |
| 5. Pressure Gauge | 11. M8 Mounting Hole |
| 6. Vent Valve | 12. Pressure Exhaust Port |

NOTICE: Air compressor power switch indicator light:

OFF: NOT pressurizing, means pressure in tank not reached set target pressure (not means no pressure inside)

BLINK: Pressurizing

ON: Pressure reached set target pressure

▲ Rear Panel



1. Power Switch
2. Power IN/OUT
3. Firing Indicator Light
4. 24V (3A) Pyro Signal Port
5. 5-pin XLR IN/OUT (5-PIN XLR IN can charge for wireless DMX pen through pin1 and 4, pin4 with DC5V power supply)
6. 3-pin XLR IN/OUT
7. E-stop Port
8. External Air Compressor Port

▲ Display and setting

1. ARM indicator light



Operators can enable/disable the arm indicator light by set the "ARM STATE" in Advanced menu. If "ARM STATE" is ON, there will be three status:

ON: no DMX signal

OFF: DMX signal input

BLINK: DMX armed

2. Welcome Interface

Software Version	CA12/36-A20240515
Serial Number	*****
Pump Run Time	00:00:00
Jet Times	XX

3. Main Interface

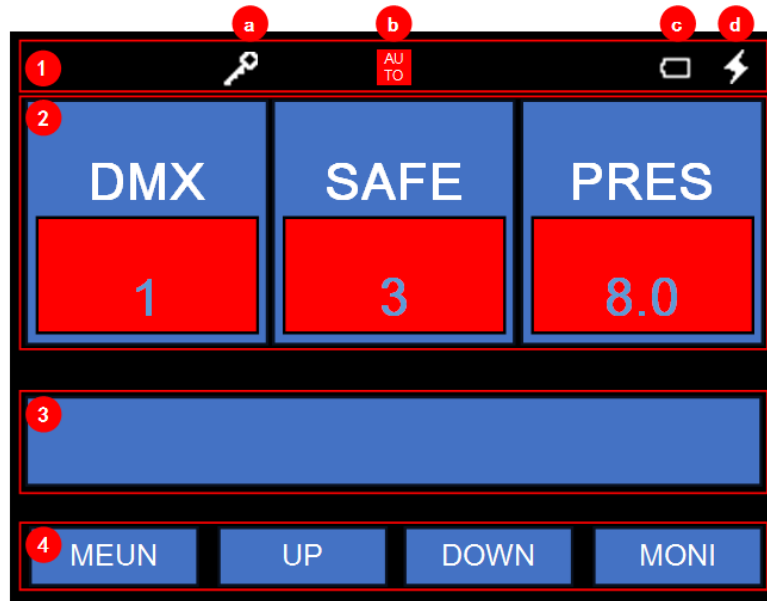

1. Status bar, 4 icons may appear in status bar



: Safety key status icon, it appears when safety key switch to "USER MODE"



: Auto pressurization icon, it appears when "automatic pressurization" setting is ON



: Battery volume



: Charging icon, it appears when uFetti Shooter is charging

2. Data bar

DMX: DMX address, Background turns from BLACK to RED when DMX cable was connected.

SAFE: Safety address, Background turns from BLACK to RED when DMX cable was connected and safety channel activated.

PRES: Pressure value. Background turns from BLACK to RED when pressure exceed "set pressure" .

3. Message bar: USER MODE / error or alert information display, Background color turns to RED when under "USER MODE" .

4. Touch Button function display

First Button: MENU / BACK

Second Button: UP / LEFT

Third Button: DOWN / RIGHT

Fourth Button: MONI / EDIT / SAVE

4. Error/Alert Message

Error/Alert Message	Why it appears	How to remove
E0 Test Mode	Safety Key Switch at TEST MODE	Switch Key to USER MODE
E0 Factory Mode	Factory mode	Switch to Normal mode
E1 Pressure Err	Pressurize time exceed system	Restart machine

	default setting time but still can't reach target pressure	
E2 P Relief Err	Pressure keep above 1bar after firing	Restart machine
E3 Press Sensor	Pressure sensor damage or disconnected	Check the pressure sensor
E4 Air Leakage	Pressure leakage	Restart machine, if error still exist please check and find out the air leakage position, and repair it accordingly.

5. Monitor Interface

Press "MONI" can enter monitor interface, press "BACK" switch back to main interface.

Menu	Explanation
Pressure	Current pressure display
DC Voltage	DC voltage of the power supply
Pressurization Enable	ON means it is pressurizing or keep pressure
BAT Voltage	Battery voltage

6. Menu Interface

Press "MENU" enter menu interface, press "LEFT" , "RIGHT" enter different items, press "BACK" switch back to main interface.

Menu	Explanation
MAIN	Main menu
ADVANCED	Advanced menu
FACTORY	Factory menu (password is required to enter)

7. Main Menu

Select "MAIN" in menu interface, press "EDIT" to enter main menu.

BACK: Back to previous interface

UP: up or +

DOWN: down or -

EDIT: Edit selected items

SAVE: Save

Items	Contents	Default	Description
Set DMX Address	1-512	1	Device DMX address
Set Safety Addr	1-512	2	Safety DMX address

MAIN	
Set DMX Address	1
Set Safety Addr	2
BACK	UP
DOWN	EDIT

8. Advanced Interface

Select "ADVANCED" in menu interface, press "EDIT" to enter advanced menu.

Items	Contents	Default	Description
Drive Test	Jet Test / Pump Test / ARM test / Close	Close	Drive test
Set Pressure	3.0-8.0BAR	8.0BAR	Target pressure, air compressor stop working after reached set pressure
ARM State	ON/OFF	ON	ARM indicator light ON/OFF setting
LCD Backlight	ON/OFF	ON	ON: LCD backlight long on OFF: LCD backlight off if no operation in a period of time
Key Sound	ON/OFF	ON	Keypad sound ON/OFF setting
Key Lock	ON/OFF	OFF	ON: Touch button will disable if there is no operation in 30s. restart machine to active touch button.
DefaultParameter	ON/OFF	OFF	Reset default parameter settings

▲ DMX CONTROL

uFetti Shooter occupies 1 functional channel CH-F and 1 separate safety channel CH-S (this channel is independent from functional channel, can be shared with other machine).

Channel	Function	Value
CH-F	Firing	0~110: NO output 111~255: Fire
CH-S	Device enable / disable	0~ 49 and 201~255: Device disabled 50~200: Device enabled

▲ Operation

1. Safety instructions

DANGER: *Make sure that confetti cannot come into contact with high-voltage lines/power pylons, as this can result in electrocution.*

DANGER: All operations must be performed by professionals, and non-professionals are prohibited from operating.

WARNING: Use of a damaged or improperly installed machine could result in death, serious injury, or property damage. Always inspect the machine thoroughly before operating it.

WARNING: Do not use the uFetti Shooter if alterations have been made other than by or on behalf of SHOWVEN.

WARNING: Make sure there are no objects that can be damaged by the machine within the output distance. And no people or animals are allowed to stay in the direct output.

WARNING: Please check tank pressure on the pressure gauge before transportation. Release the pressure with Vent Valve.

WARNING: The noise level near the machine is high at the moment of firing, so the operator should wear hearing protection.

WARNING: Before operating the machine, be sure to lock the output pipe and install the safety rope

WARNING: The red cone area shown in below picture is the safe isolation range of this product, and unauthorized persons or objects are strictly prohibited from entering. $A=40m$, $B=50^\circ$, $a=5m$.

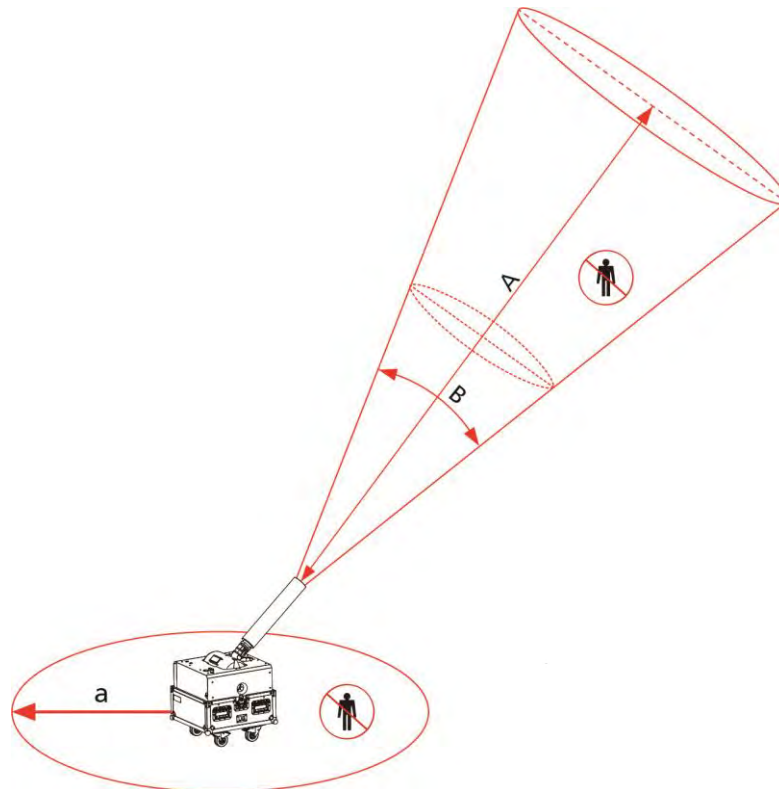

NOTICE: Make sure the brake of 4 casters are locked. And all four wheels are on ground.

2. Install uFetti Shooter

2.1 Bring the machine to desired location.



2.2 Lock all four casters of the machine.



2.3 Unlock and remove the flight case cover



2.4 Take out the output pipe.



2.5 Adjust the output angle of output pipe, make sure angle plunger is locked.



WARNING: *Make sure the angle plunger is well locked in properly place. Not doing so can result in serious injury or death.*

3. Battery installation (if operator prepared the 18650 batteries; only available for CA12)

uFetti Shooter can be powered through 16 pcs of 18650 cells. New uFetti Shooter come only with battery compartment, customer need to get 18650 cells locally. The battery we suggest to use is with flat head as below:

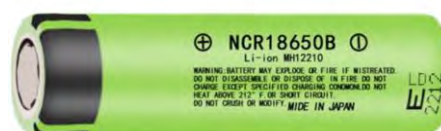

The battery installation steps:

- a) Unscrew the screws of the battery box at the side panel as below.
- b) Install the battery in correct direction, pay attention to the positive and negative pole.
- c) Press and hold the reset button (as show in the red circle below) for 1s to activate battery.

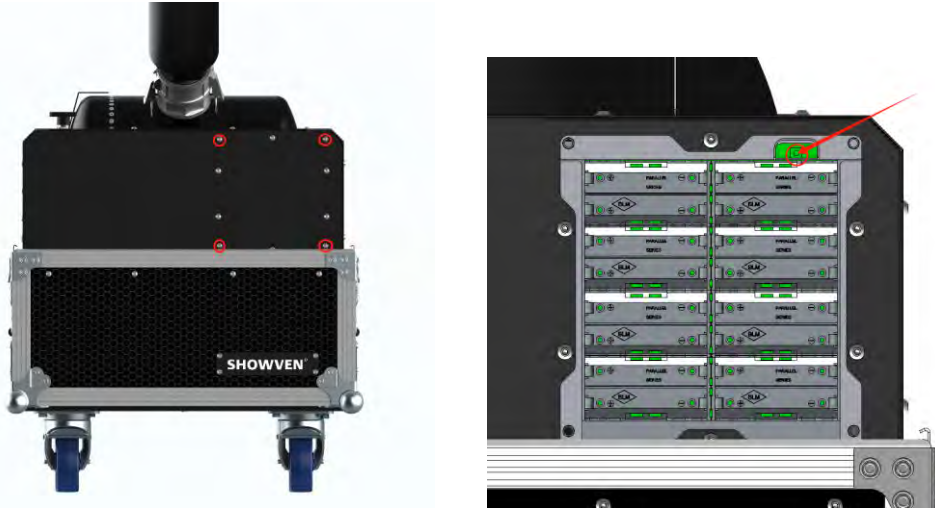

- d) Install back the battery box plate.
- e) Charging: charging automatically when machine connected with AC power supply (no matter machine was powered on or not)

WARNING: Install the battery with reverse polarity may cause short circuit, resulting in fire or explosion risk.

NOTICE: To avoid the damage of battery, charge the battery at least once per month.

NOTICE: 18650 battery activation is necessary whenever install the battery

4. Fill the machine with confetti / streamers

- 3.1 Place a lifting core at the bottom of the output pipe, make sure the lifting core is lies flat at the bottom of output pipe and close the hole.
- 3.2 Fill the output pipe with confetti / streamers.

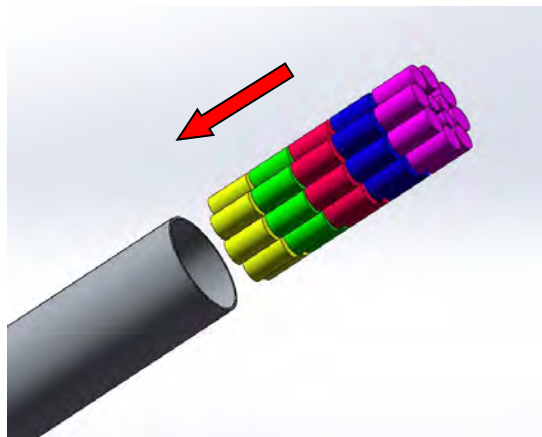

- 3.3 Place a pressure cap on top of the output pipe, and secure with special cap tape, suggest

to wrap 2 turns.

WARNING:

For the best output effect, we suggest to fill confetti / streamers in order and layer by layer. For streamers please avoid rolls loosen.

5. Output Pipe Installation

4.1 Pull the ring of self-locking quick coupler downwards.

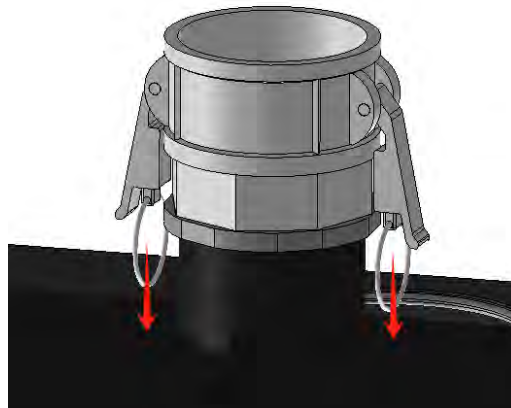

4.2 Rotate the ring upward to release the lock

4.3 Place the output pipe in the quick coupler

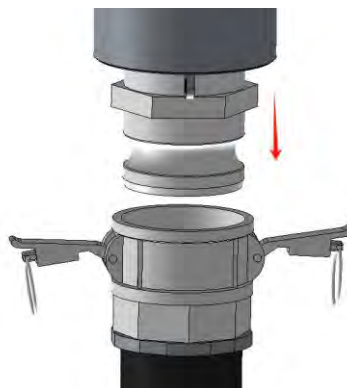

4.4 Lock the output pipe in place with the locking clamps

4.5 Double confirm output pipe is well locked



4.6 Connect the output pipe with tank through safety rope

WARNING:

Never use the machine if the clamps are not locked or working properly, it may result in serious injury or death.

NOTICE:

Check whether the rubber sealing ring of quick coupler in it' s position (it is a black circle ring) before install the output pipe. Operator can feel resistance if the rubber sealing ring is well installed in place when install the output pipe.

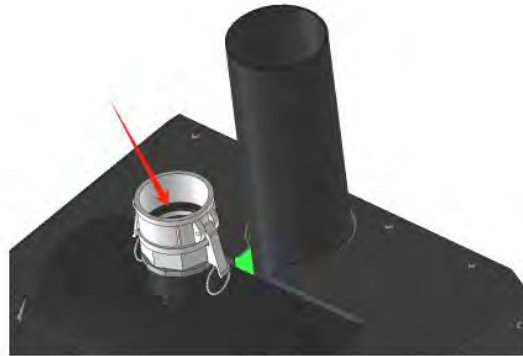

6. E-Stopper / E-stop terminator Connection

E-stop interface is a power cut-off interface, the machine can be powered on normally only when E-STOP in is connected. For safer use of uFetti Shooter we suggest to connect it with E-stopper. For operators who don' t want to use E-stopper can plug a E-stop terminator in E-STOP IN to enable the device.

E-Stopper (optional) connect with single unit of uFetti Shooter.



E-Stopper (optional) connect with multi units of uFetti Shooter in daisy chain.



NOTICE:

An unit of E-Stopper can control maximum 24 units of device.

Use E-stop terminator (standard configuration) if without E-Stopper. Plug the E-stop terminator to the E-STOP IN port.



7. Power and DMX cable connection

a) Connect a power cable to the POWER IN socket of uFetti Shooter. Connect the other end of power cable to the power source. Make sure power supply is consistent with the rated voltage of the equipment, and the socket must be well grounded. Or use battery if installed battery inside.

b) Power ON uFetti Shooter

DMX control, Please follow below steps:

c) Connect a DMX cable to the DMX IN socket of first unit of uFetti Shooter, another head of this DMX cable connect to DMX console (such as FXcommander). Make sure the DMX console is powered off.

d) Connect a DMX cable to the DMX OUT socket of previous uFetti Shooter, and the other end to the DMX IN of next machine. Connect all devices in series in this way.

e) Suggest to plug in a DMX terminator into the DMX OUT in last unit of machine to improve signal reliability. For distance >200m please use SHOWVEN DMX splitter 8 to amplify the signal.

f) Assign DMX address for each unit of uFetti Shooter. If use SHOWVEN host controller or FXcommander to control the machine please allocate a unique DMX address for each unit of machine.

g) Power ON DMX console

If control by 24V pyro signal, follow below steps:

a) Connect the power control cables to the 24V pyro signal connector on uFetti Shooter.

b) Connect the other end of power control cables to the pyro slave (24V external trigger source), such as SHOWVEN PyroSlave series module. Before connect please make sure there is no pyro signal input.

CAUTION: *It is possible to fire the machine with 24V 3A pyro signal even without power on the machine.*

8. Pressurize the machine

uFetti Shooter with built-in air compressor as well as equipped with external air compressor port, so it can work with both built in or external air compressor.

Work with built-in air compressor:

Close the vent valve, press the "air compressor power switch" on uFetti Shooter top panel to activate air compressor. The background color of PRES on LCD screen turn red and display current pressure. Air compressor stop working after reached set pressure.

Work with external air compressor:

- a) Connect the hose (10mm) with Festo quick coupler female (optional parts RMMET567) , and connect the quick coupler with external air compressor port on uFetti Shooter, the other end of the hose connect with external air compressor.
- b) Close the vent valve. Start the external air compressor, after uFetti Shooter reached target pressure please power of external air compressor.

WARNING: *when use external air compressor, the max pressure should not above 8Bar. uFetti Shooter tank equipped with safety valve if pressure is too high it will open the release pressure automatically (safety threshold is 9.6Bar / 140PSI) .*

9. Firing (DMX or Pyro control)

Double confirm the prescribed safety isolation zone is clear, no person, animal or other property within this region. Double confirm the output pipe and angle plunger are both locked well.

Switch the safety key to USER MODE.

DMX signal control:

- a) Activate the safety channel and enable device, the ARM indicator light blinking.
- b) Set the DMX value for the effect channel between 111-255 to firing or use SHOWVEN FXbutton or FXcommander to firing.

Pyro signal control:

- a) Match the FXcommander / PyroMote with PyroSlave.
- b) Switch the pyro arm on FXcommander / PyroMote to ON status.
- c) Program the cue.
- d) Firing.

Output distance

The output height, width and distance depend on the type of confetti / streamers, the output angle, setting pressure etc.

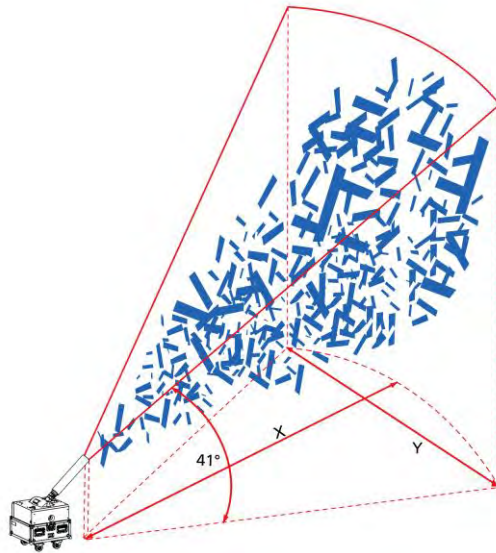

(1) uFetti Blower CA12

Consumable Type	Size	Max. Output Distance 41°(X)	Max. Output Width (Y)
Paper Confetti	55 * 17cm	22m	10m
Metallic Confetti	55 * 17cm	22m	10m
Streamers	20m * 5cm	43m	15m
Streamers	20m * 2.5cm	35m	15m
Streamers	10m * 5cm	25m	13m

(2) uFetti Blower CA36

Consumable Type	Size	Max. Output Distance 41°(X)	Max. Output Width (Y)
Paper Confetti	55 * 17cm	22m	10m
Metallic Confetti	55 * 17cm	22m	10m
Streamers	20m * 5cm	45m	15m
Streamers	20m * 2.5cm	35m	15m
Streamers	10m * 5cm	25m	13m

NOTICE: *The above parameters are test parameters with SHOWVEN original confetti under ideal conditions with no wind, and the output pipe is set at 41 degrees.*

WARNING: *For confetti / streamers not from SHOWVEN may not achieve the expected results or even cause property damage.*

10. Power OFF and clean up

- a) Open the vent valve to release the pressure and make sure the gauge pressure is 0 bar.
- b) Switch the safety key to TEST MODE

- c) Power OFF uFetti Shooter, disconnect power and/or DMX cables.
- d) Rotate the tank / output pipe to vertical up position (0 degree). This step is very important.
- e) Pull the ring of self-locking quick coupler downwards, rotate the ring upward to release the lock.

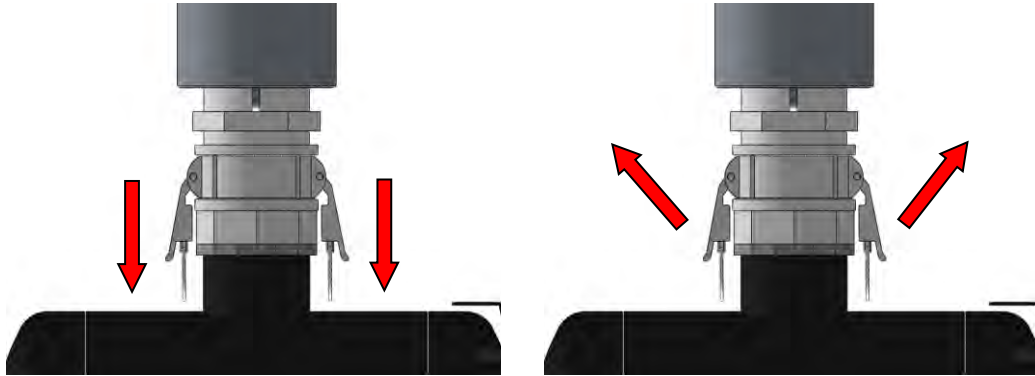

- f) Disconnect the safe rope and remove the output pipe from the quick coupler.

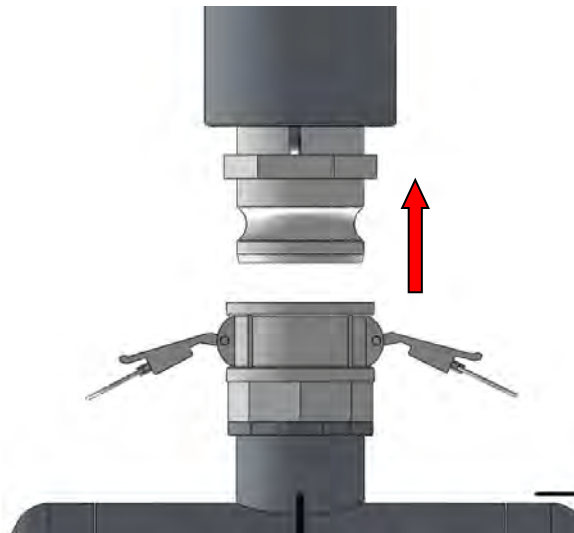

- g) Store the output pipe in the flightcase

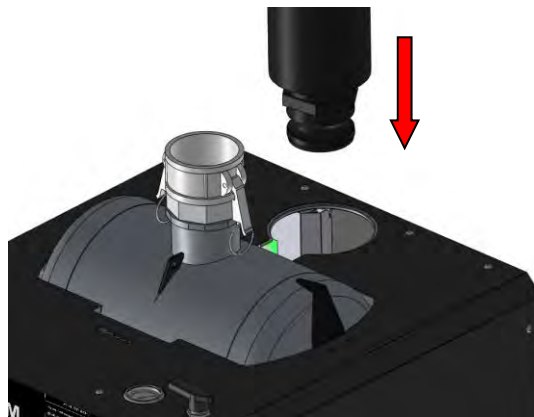

- h) Place and lock the flightcase cover.



i) Release the brakes for casters.



▲ Maintenance

1. Air filter replacement

This machine is equipped with a built-in air compressor. Depending on the use environment, the maintenance cycle is not an absolute time. In a relatively clean environment with less dust, maintenance is recommended **every 12 months**; in an environment with more dust, maintenance is recommended **every 6 months**.

a) Remove the left handle.



- b) Disassemble the air filter

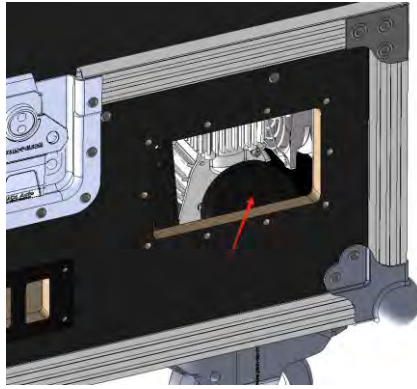

- c) Remove the top cover of air filter with straight screwdriver
d) Replace the internal filter cotton



- e) Install back the filter cover, air filter and handle.

NOTICE: *The air compressor will be quite hot after running, It is recommended to replace the air filter half an hour later after the air compressor stops.*

2. Tank drain operation.

This machine is equipped with an oil-water separator, but it cannot completely filter out the moisture in the air, so it is recommended to perform a drain operation. We recommend to make a tank drain operation **every 3 months**; if machine use with high frequency please make more frequent drain operation accordingly.

- a) Power OFF the machine, disconnect with power supply, and emptying pressure in tank.
- b) Adjust the output pipe to position 0 direction.
- c) Open the drain valve at the bottom of the tank (before opening, you need to place an empty cup in the drain to collect the discharged sewage) and wait for the air in the tank to drain out.
- d) Close the drain valve.

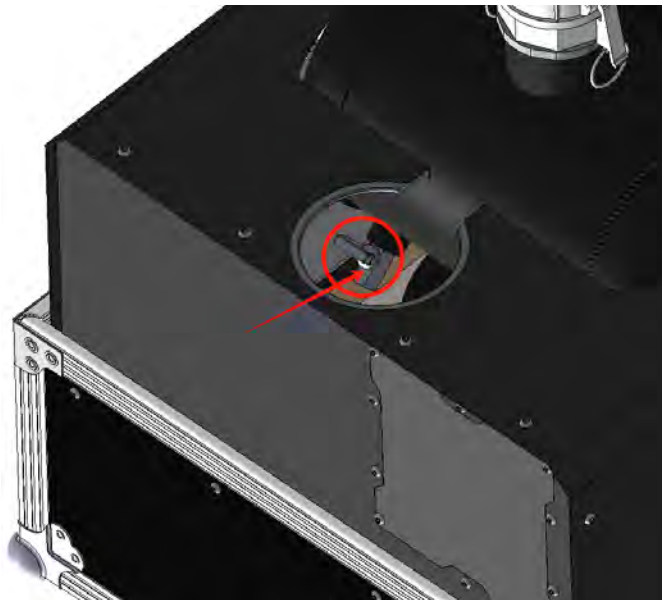

WARNING: *Make sure the safety key stay at TEST MODE, and machine is stay at power OFF status, otherwise it may result in serious injury or death..*

▲ Optional Parts for uFetti Shooter

1 uFetti Blower CA12

Part. No.	Description	pcs / unit
SFCAB258	EU NEUTRIK PowerCON TRUE1 cable - 3m	1
SFCAB051	US NEUTRIK PowerCON TRUE1 cable - 3m	1
RMMET641	Built-in air compressor filter (CA12 CA36)	1
RMMET618	CA12 pressure cap	2
RMMET620	CA12 lifting core	2
RMGLU041	Tape (50m*50mm, black)	1
RMSTE1473	Output pipe for CA12 (5L)	1
RMMET622	Safety rope (diameter 5mm, length 300mm)	1
SFMET1107	G1-E-Stop Terminator	1
RMMET516	G1-Anti-static battery disassembly spudger	1
RMMET567	Festo quick coupler female KD4-1_4-A-R (Festo)	1
RMBOT036	Safety loop M8	
SFCHC265	CA12 10 caps +10 cores	

2 uFetti Blower CA36

Part. No.	Description	pcs / unit
SFCAB258	EU NEUTRIK PowerCON TRUE1 cable - 3m	1
SFCAB051	US NEUTRIK PowerCON TRUE1 cable - 3m	1
RMMET641	Built-in air compressor filter (CA12 CA36)	1
RMMET619	CA36 pressure cap	2
RMMET621	CA36 lifting core	2
RMGLU041	Tape (50m*50mm, black)	1
RMSTE1474	Output pipe for CA36 (10L)	1
RMMET622	Safety rope (diameter 5mm, length 300mm)	1
SFMET1107	G1-E-Stop Terminator	1
RMMET567	Festo quick coupler female KD4-1_4-A-R (Festo)	1
RMBOT036	Safety loop M8	
SFCHC267	CA36 10 caps +10 cores	

▲ Warranty Instructions

- \ Sincere thanks for your choosing our products, you will receive quality service from us
- \ The product warranty period is one year. If there are any quality problems within 7 days after shipping out from our factory, we can exchange a brand new same model machine for you
- \ We will offer free of charge maintenance service for machines which with hardware malfunction (except for the instrument damage caused by human factors) in warranty period. Please don't repair machine without factory permission

Below situations NOT included in warranty service:

- \ Damage caused by use unqualified consumables;
- \ Damage caused by improper transportation, usage, management, and maintenance, or damage caused by human factors;
- \ Disassemble, modify or repair products without permission;
- \ Damage caused by external reasons (lightning strike, power supply etc.)
- \ Damage caused by improper installation or use;

For product damage not included in warranty range, we can provide paid service.

Invoice is necessary when applying for maintenance service from SHOWVEN

**ASK US FOR YOUR
PROFESSIONAL PRICES !**

SHOWVEN[®]

PREMIUM FACTORY SAS - DISTRIBUTEUR OFFICIEL
1 Route Neuve, 71710 MONTCENIS – FRANCE
Office +33 805 69 13 27 | +33 608 630 452
info@premiumfactory.eu | www.premiumfactory.eu