

USER MANUAL

SPARKULAR® WHEEL

V1.0

2025/02/19



Showven Technologies Co., Ltd.

Thanks for choosing SPARKULAR® WHEEL, we wish it will sparks up your show. Please read the following manual carefully before operating this product.

Δ Safety Instructions

- ⚠ Unauthorized repair are prohibited, it may cause serious incident.
- ⚠ SPARKULAR® WHEEL can be used in rain, please keep the device dry after use.
- ⚠ Make sure lid of feeding hopper are well covered when use SPARKULAR® WHEEL.
- ⚠ Consumable should keep away from moisture and stored in a dry sealed environment.
- ⚠ Check whether there is consumable aggregate in the output nozzle both before and after each show, if any, please clean it up, or it will affect the firing effect, damage machine, even cause serious incident.
- ⚠ There will be some sparks drop to ground, make sure there are no flammable objects such as carpet on the ground within the safety radius of the machine.
- ⚠ The SPARKULAR® WHEEL power supply cable maximum allowed cascade of 6pcs (220V version) / 3pcs (110V version), exceed connecting may result in damage or even cause fire.
- ⚠ Cover the output nozzle of SPARKULAR® WHEEL is forbidden, inspect the machine before each show, making sure no objects or material will block the output nozzle.
- ⚠ Never touch the nozzle of SPARKULAR® WHEEL danger of getting burnt.
- ⚠ Never touch the sparks which shooting out from the nozzle.
- ⚠ Make sure no staff, audience and flammable materials stays under the SPARKULAR® WHEEL.

Safety Distance

- ⚠ Safety distance for SPARKULAR® WHEEL divided into two parts safety radius around machine (a) and safety distance at firing direction (b). No person and flammable materials are allowed to stay inside the safety isolation zone when SPARKULAR® WHEEL was armed.
- ⚠ The safety radius around machine of 1.5m.
- ⚠ For safety distance at firing direction equals to maximum firing height + 1m. SPARKULAR® WHEEL with 360 degree rotation firing angles, when firing wave sequence the safety isolation zone is a three-dimensional sector area.

Firing Direction	Max. Effect Height	Safety Radius around SPARKULAR (a)	Safety Distance at Firing Direction (b)
Vertical Up	4m	1.5m	5m
Vertical Down	7m		8m
360° rotate	3m Radius		4m

- ⚠ When under full cycle mode, SPARKULAR® WHEEL safety isolation zone is a three-dimensional space with a circular cross-section with radius of b, and thickness of 2a, as show in below picture. Unauthorized persons and objects are strictly prohibited from entering. Depending on the firing sequence / angles the safety isolation area changes accordingly.
- ⚠ In windy environment, increase the safety distance according to the wind direction and speed.
- ⚠ Sparks and consumables from the machine can lead to serious eye injury. Always wear safety goggles when enter the safety zone.

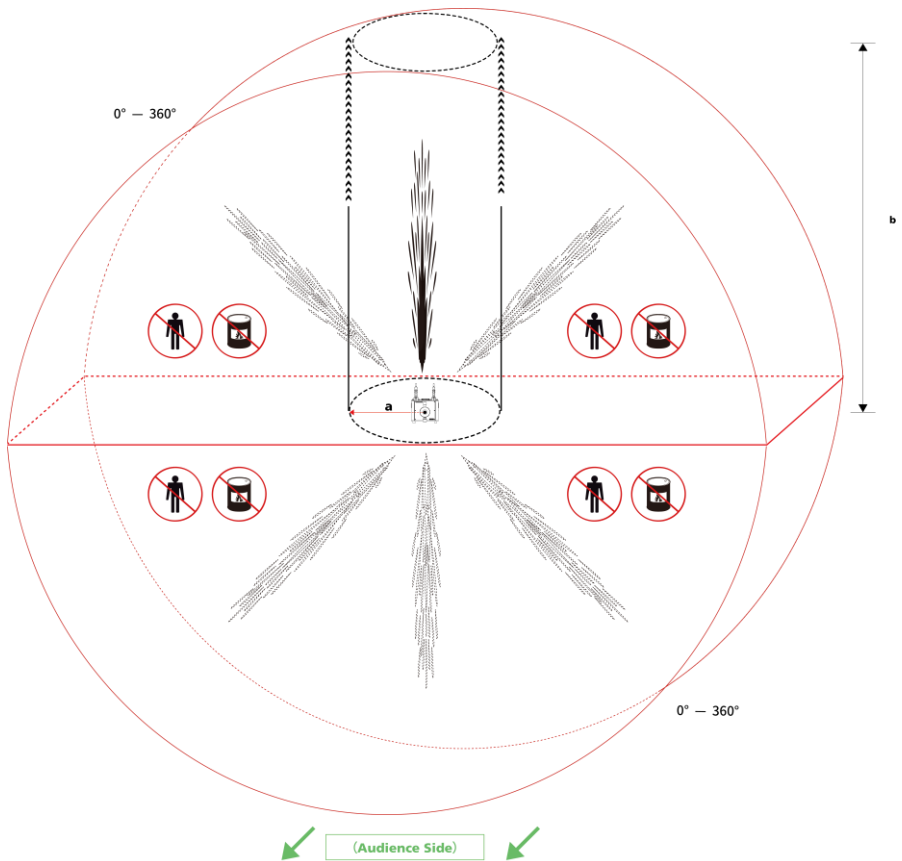

Δ Description

SPARKULAR® WHEEL is another brand new sparks effects originally introduced by SHOWVEN®. It is a SPARKULAR® machine with versatile output angles, the output nozzle can rotate 360 degrees and can also fire in any fixed direction. Thus it can simulate the molten iron flow effect, if combined several units together it can also generate fireworks wheel effects. It is versatile for both big stages and small wedding gatherings.

Δ Technical Specifications

\ **MODEL:** BT83

\ **DIMENSION:** 318×307×285mm

\ **WEIGHT:** 15kg

\ **VOLTAGE:** AC 100-240V, 50/60Hz

\ **WORK POWER:** 500W

\ **HC8200 CONSUMPTION:** 50g/min

\ **EFFECT HEIGHT ADJUSTBLE:** YES, height level gear 1-3

\ **EFFECT ANGLE ADJUSTBLE:** 0°~ 360°

\ **INTERFACE:** 3-pin and 5-pin XLR, POWER IN/OUT

\ **CONTROL:** 6 DMX channels

\ **WORK TEMP.:** -20°C~40°C

\ **CONSUMABLE AND EFFECT HEIGHT:** HC8200 LARGE, vertical up 4m, vertical down 6-7m, 360° rotate with radius of 2.5-3m.

Δ Structure of SPARKULAR® WHEEL

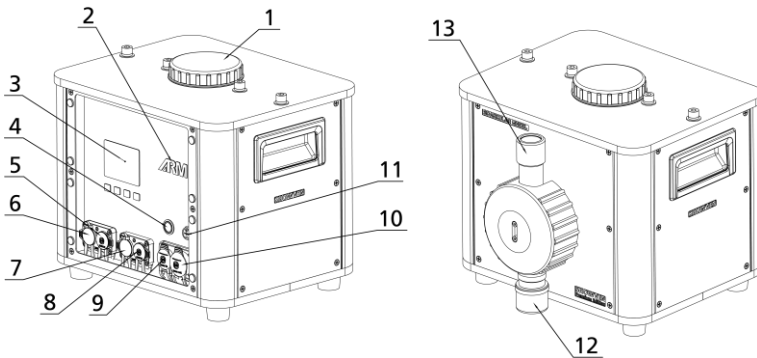

1. Feeding Hopper Lid
2. ARM alarming light
3. Display Screen
4. Power Switch (flash means machine is heating up, long on means temp. reached setting temp.)
5. 5-PIN DMX IN
6. 5-PIN DMX OUT
7. 3-PIN DMX OUT
8. 3-PIN DMX IN
9. Power IN
10. Power OUT
11. Fuse
12. Blower
13. Output Nozzle

Δ Operation Panel

1. Keypad area

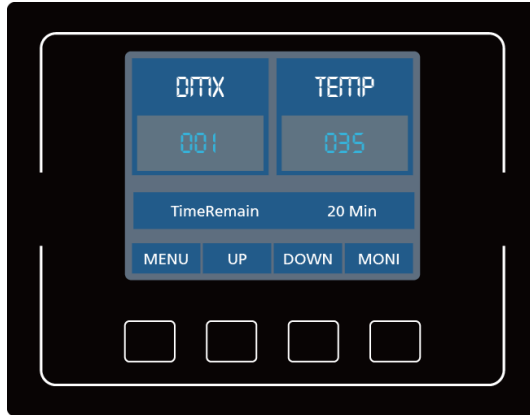

MENU: Press enter setting interface

UP: Parameter up

DOWN: Parameter down

MONI: Status monitoring of main part inside machine

2. Monitoring Interface

From this interface, we can check the PCB Temp, fan speed, motor status, voltage etc. to monitoring the critical parts status of the machine.

MONITOR			
PCBA Temperature	0		
Fan Out	85.2%		
Blower Motor Sensor	00.0A		
Shaft Motor Sensor	00.0A		
Feeding Motor Sensor	00.0A		
Hall Sensor	1		
DC Voltage	24.1v		
BACK	UP	DOWN	MONI

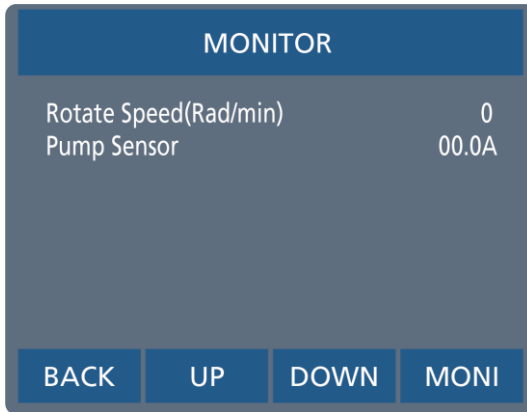

3. RFID area

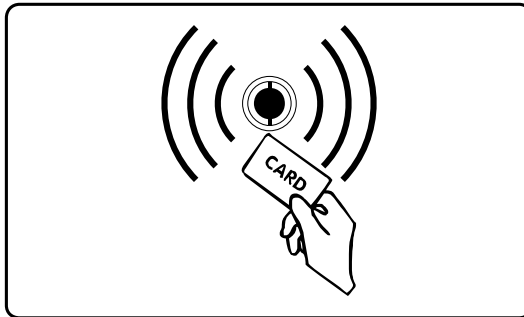

RFID card come with consumable HC8200 bags, swiping card to identify parameters and types of granules. The RFID card is disposable, one card can only use one time. Each card can increase single machine 20min working time, the maximum recharge time for SPARKULAR® WHEEL is 30min. SPARKULAR® WHEEL any compatible with V2.0 RFID card.

4. ARM alarming light



OFF: DMX connected

BLINK: DMX armed, ready for firing

ON: No DMX connection

NOTE: you can turn off the ARM light in ADVANCED menu by switch the ARM State to OFF status.

Δ Display Interface

1. Main Interface:

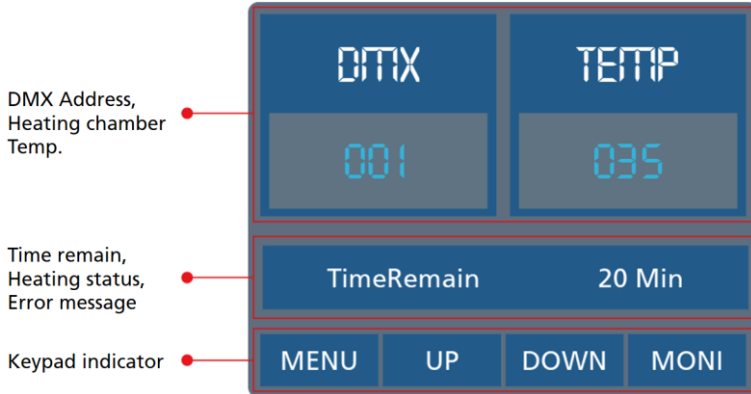

Background color of DMX area: RED means DMX connected.

Background color of TEMP area: RED means heating chamber temp. reached setting temp. machine is ready for firing.

2. Error information

Error information	Explanation
E0 System IC3	Systematic error, use fake RFID card
E1 Blower Motor Stall	Blower motor over current
E1 Blower Motor Unconnect	Blower motor current is too small
E1 Shaft Motor Stall	Shaft motor over current
E1 Feeding Motor Stall	Feeding motor over current
E2 Temp. Sensor	Temperature sensor is not connected or damaged
E3 P Temp. Over	Chassis over temperature
E4 Time Remain	Firing time is insufficient (less than 10min), please swipe RFID card
E5 K Temp. Over	Machine shutdown due to heating chamber over temperature
E6 Heat Fail	Heating up time too long lead to heat fail, problem on heating PCB or mainboard, if disappear automatically, please check the power supply.
E7 Tip Over	Tilt sensor activated when machine slant over 45 degrees
E8 Angle_Err	Output nozzle can not be centered itself

3. Set Up Menu

Press "MENU" enter setup menu, press LEFT, RIGHT to choose main menu, advanced menu, test menu or factory menu. Press "EIDT" can entering related menu and setting up related parameters.

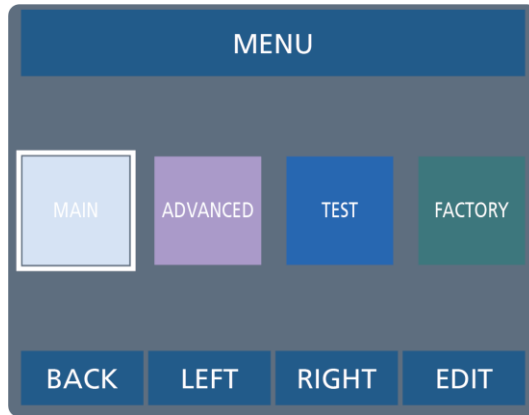

4. Main Menu

Parameters in main menu show in below table, press "UP"/ "DOWN" to change the value, please remember to press "SAVE" to save the setting.

Options	Range	Default	Explanation
Set DMX Address	1-507	1	Set DMX Address
Sequence	2 - 95	2	Preset sequence setting when manual firing or remote control
Manual Heat	ON/OFF	OFF	Manual heat ON/OFF setting
Manual Fountain	ON/OFF	OFF	Manual Fountain ON/OFF setting

5. Advanced Menu

Options	Range	Default	Explanation
Set Temperature	520-620	580	Heating chamber temperature setting
Wireless Control	ON/OFF	OFF	Wireless function setting
Density	50-100	100	Feeding amount
Motor Protect	ON/OFF	ON	Motor protect function ON/OFF
Tip Over	ON/OFF	ON	Tilt function switch, when machine slant over 45 degree it will stop working.
Standby Switch	ON/OFF	OFF	When ON, the machine can firing only when heating up was finished
ARM State	ON/OFF	ON	ARM indicator light ON/OFF setting
Mode Selection	Factory Mode	User Mode	Factory mode is for factory use only.

	User Mode		When in Factory mode machine can't controlled by DMX console
LCD Backlight	ON/OFF	ON	LCD backlight setting
Auto Clear Delay	0.1-0.9s	0.1s	Automatic clear material time setting
Key Sound	ON/OFF	ON	Keypad press sound setting
Key Lock	ON/OFF	OFF	Keypad auto lock after 30s no operation. Restart to unlock the Key Lock.
Default Parameter	ON/OFF	OFF	Parameters reset to default setting

*For better performance of SPARKULAR[®] WHEEL, please don't change the default value without permission from SHOWVEN[®].

6. Test Menu

Options	Explanation
Blower Test	Blower function testing
Shaft Test	Shaft motor testing
Feeding Test	Feeding motor testing
Pump Test	Pump testing
Synthesize Test	Comprehensive testing

7. DMX Channel Mode

SPARKULAR[®] WHEEL occupies 6 operational channels.

Channel	Function	Value
CH1	Manual Angle setup	0~255: angle change from 0° to 720° 128: straight upward
CH2	Manual Nozzle Waving Speed setup	0 and 255: Max Speed 1~254: Speed increase
CH3	Firing ON/OFF	0~15: Firing OFF 16~90: Firing height low 91~170: Firing height medium 171~255: Firing height high Maxi. Single firing duration is 180s
CH4	n/a	Reserved
CH5	Preset sequence setup	0-2: no preset sequence 3-255: preset sequence DMX value = 2 + Sequence No.*2.55 (ROUND OFF)
CH6	Mode setup	0~49: Heating Up OFF (Emergency Stop) 50~200: Heating Up ON 201~255: Heating Up OFF (Emergency Stop)

NOTE: Sequence No. 10 and No.11 output tube rotate speed can adjust throught channel 2.

Channel 1 (CH1): Manual Angle Setup

This angle can be selected anywhere from 0° to 720° (DMX value from 1 to 255). The following formula can be used to calculate the angle ∠ (in degrees);

$$\text{DMX Value} = \angle \times 2.804 + 1$$

SPARKUALR® WHEEL output nozzle firing angle can be 720° (360° * 2), from the audience view, 0° start from vertical up 12 o'clock direction, every 15° degree a firing position, all together 49 postions.

Angle No.	Angle	Angle No.	Angle	Angle No.	Angle
A1	0°	A2	360°	A3	720°
B1	15°	B2	375°		
C1	30°	C2	390°		
D1	45°	D2	405°		
E1	60°	E2	420°		
F1	75°	F2	435°		
G1	90°	G2	450°		
H1	105°	H2	465°		
I1	120°	I2	480°		
J1	135°	J2	495°		
K1	150°	K2	510°		
L1	165°	L2	525°		
M1	180°	M2	540°		
N1	195°	N2	555°		
O1	210°	O2	570°		
P1	225°	P2	585°		
Q1	240°	Q2	600°		
R1	255°	R2	615°		
S1	270°	S2	630°		
T1	185°	T2	645°		
U1	300°	U2	660°		
V1	315°	V2	675°		
W1	330°	W2	690°		
X1	345°	X2	705°		

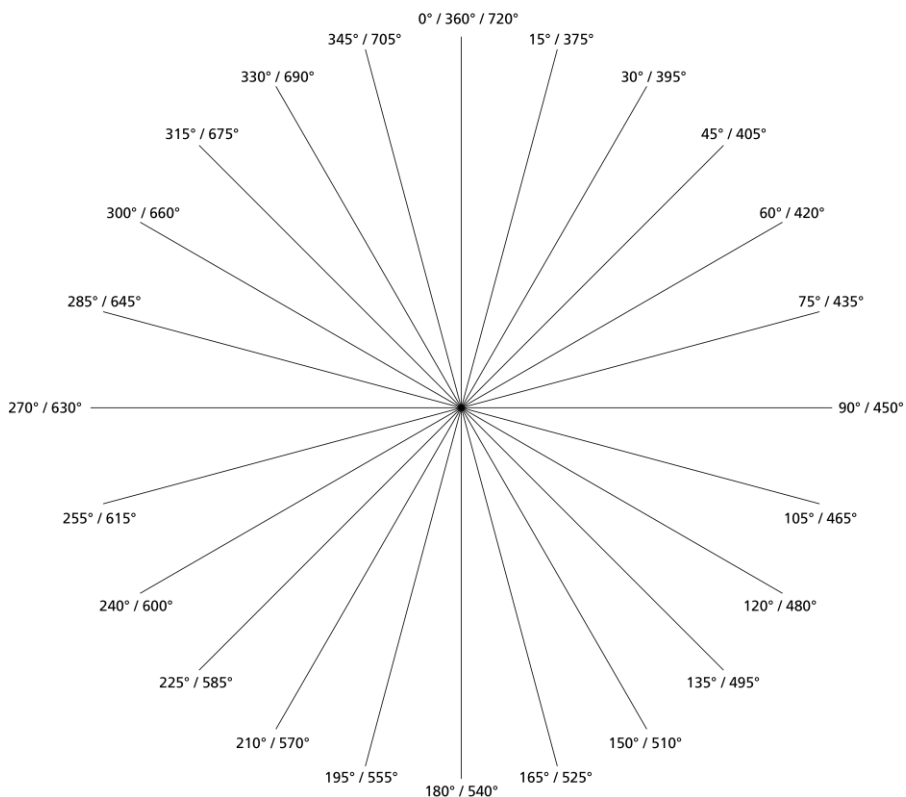

Channel 5 (CH5): Firing Sequence

SPARKULAR® WHEEL has 93 preset sequences, operator use related channel DMX value or sequence No. to access certain sequence. Below, you can find sequence list.

No.	Ignition angle	Description	Firing Duration	CH5 DMX Reference Value
1	Any angle	Clear material	Depends on CH3	3-5
2	0°	Fixed angle firing	Depends on CH3	6-7
3	45°	Fixed angle firing	Depends on CH3	8-10
4	90°	Fixed angle firing	Depends on CH3	11-12
5	135°	Fixed angle firing	Depends on CH3	13-15
6	180°	Fixed angle firing	Depends on CH3	16-17
7	225°	Fixed angle firing	Depends on CH3	18-20
8	270°	Fixed angle firing	Depends on CH3	21-22
9	315°	Fixed angle firing	Depends on CH3	23-25
10	clockwise	Multi cycles	Depends on CH3	26-28

11	anticlockwise	Multi cycles	Depends on CH3	29-30
12	clockwise	Medium 2 cycles	2.60s	31-33
13	anticlockwise	Medium 2 cycles	2.60s	34-35
14	clockwise	Slow 2 cycles	6.50s	36-38
15	anticlockwise	Slow 2 cycles	6.50s	39-40
16	A1-G2-A1 (0°~450°~0°)	Medium waving	Depends on CH3	41-43
17	I1~O2~I1 (120°~570°~120°)	Medium waving	Depends on CH3	44-45
18	Q1~W2~Q1 (240°~690°~240°)	Medium waving	Depends on CH3	46-48
19	A1-G2-A1 (0°~450°~0°)	Slow waving	Depends on CH3	49-50
20	I1~O2~I1 (120°~570°~120°)	Slow waving	Depends on CH3	51-53
21	Q1~W2~Q1 (240°~690°~240°)	Slow waving	Depends on CH3	54-56
22	S1-A2-G2 (270°~360°~450°)	Upper half circle L to R fast waving 5 times	1.65s	57-58
23	G2-A2-S1 (450°~360°~270°)	Upper half circle R to L fast waving 5 times	1.65s	59-61
24	G2-M2-S2 (450°~540°~630°)	Lower half circle R to L fast waving 5 times	1.65s	62-63
25	S1-M1-G1 (270°~180°~90°)	Lower half circle L to R fast waving 5 times	1.65s	64-66
26	A2-S1-M1 (360°~270°~180°)	Left half circle up to down fast waving 5 times	1.65s	67-68
27	M1-S1-A2 (180°~270°~360°)	Left half circle down to up fast waving 5 times	1.65s	69-71
28	A2-G2-M2 (360°~450°~540°)	Right half circle up to down fast waving 5 times	1.65s	72-73
29	M2-G2-A2 (540°~450°~360°)	Right half circle down to up fast waving 5 times	1.65s	74-76
30	S1-A2-G2 (270°~360°~450°)	Upper half circle L to R medium waving 3 times	3.96s	77-79
31	G2-A2-S1 (450°~360°~270°)	Upper half circle R to L medium waving 3 times	3.96s	80-81
32	G2-M2-S2 (450°~540°~630°)	Lower half circle R to L medium waving 3 times	3.96s	82-84
33	S1-M1-G1 (270°~180°~90°)	Lower half circle L to R medium waving 3 times	3.96s	85-86
34	A2-S1-M1 (360°~270°~180°)	Left half circle up to down medium waving 3 times	3.96s	87-89
35	M1-S1-A2 (180°~270°~360°)	Left half circle down to up medium waving 3 times	3.96s	90-91
36	A2-G2-M2 (360°~450°~540°)	Right half circle up to down medium waving 3 times	3.96s	92-94
37	M2-G2-A2 (540°~450°~360°)	Right half circle down to up medium waving 3 times	3.96s	95-96
38	S1-A2-G2	Upper half circle L to R	6.6s	97-99

	(270°~360°~450°)	slow waving twice		
39	G2-A2-S1 (450°~360°~270°)	Upper half circle R to L slow waving twice	6.6s	100-101
40	G2-M2-S2 (450°~540°~630°)	Lower half circle R to L slow waving twice	6.6s	102-104
41	S1-M1-G1 (270°~180°~90°)	Lower half circle L to R slow waving twice	6.6s	105-107
42	A2-S1-M1 (360°~270°~180°)	Left half circle up to down slow waving twice	6.6s	108-109
43	M1-S1-A2 (180°~270°~360°)	Left half circle down to up slow waving twice	6.6s	110-112
44	A2-G2-M2 (360°~450°~540°)	Right half circle up to down slow waving twice	6.6s	113-114
45	M2-G2-A2 (540°~450°~360°)	Right half circle down to up slow waving twice	6.6s	115-117
46	A2-G2-A2 (360°~450°~360°)	Fast waving 10 times	1.6s	118-119
47	G2-A2-G2 (450°~360°~450°)	Fast waving 10 times	1.6s	120-122
48	A2-S1-A2 (360°~270°~360°)	Fast waving 10 times	1.6s	123-124
49	S1-A2-S1 (270°~360°~270°)	Fast waving 10 times	1.6s	125-127
50	S1-M1-S1 (270°~180°~270°)	Fast waving 10 times	1.6s	128-130
51	M1-S1-M1 (180°~270°~180°)	Fast waving 10 times	1.6s	131-132
52	G2-M2-G2 (450°~540°~450°)	Fast waving 10 times	1.6s	133-135
53	M2-G2-M2 (540°~450°~540°)	Fast waving 10 times	1.6s	136-137
54	V1-D2-V1 (315°~405°~315°)	Fast waving 10 times	1.6s	138-140
55	D2-V1-D2 (405°~315°~405°)	Fast waving 10 times	1.6s	141-142
56	V1-R1-V1 (315°~225°~315°)	Fast waving 10 times	1.6s	143-145
57	R1-V1-R1 (225°~315°~225°)	Fast waving 10 times	1.6s	146-147
58	D2-J2-D2 (405°~495°~405°)	Fast waving 10 times	1.6s	148-150
59	J2-D2-J2 (495°~405°~495°)	Fast waving 10 times	1.6s	151-152
60	R1-J1-R1 (225°~135°~225°)	Fast waving 10 times	1.6s	153-155
61	J1-R1-J1 (495°~585°~495°)	Fast waving 10 times	1.6s	156-158
62	A2-G2-A2 (360°~450°~360°)	Medium waving 5 times	3.2s	159-160
63	G2-A2-G2 (450°~360°~450°)	Medium waving 5 times	3.2s	161-163
64	A2-S1-A2 (360°~270°~360°)	Medium waving 5 times	3.2s	164-165

65	S1-A2-S1 (270°~360°~270°)	Medium waving 5 times	3.2s	166-168
66	S1-M1-S1 (270°~180°~270°)	Medium waving 5 times	3.2s	169-170
67	M1-S1-M1 (180°~270°~180°)	Medium waving 5 times	3.2s	171-173
68	G2-M2-G2 (450°~540°~450°)	Medium waving 5 times	3.2s	174-175
69	M2-G2-M2 (540°~450°~540°)	Medium waving 5 times	3.2s	176-178
70	V1~D2~V1 (315°~405°~315°)	Medium waving 5 times	3.2s	179-181
71	D2~V1~D2 (405°~315°~405°)	Medium waving 5 times	3.2s	182-183
72	V1~R1~V1 (315°~225°~315°)	Medium waving 5 times	3.2s	184-186
73	R1~V1~R1 (225°~315°~225°)	Medium waving 5 times	3.2s	187-188
74	D2~J2~D2 (405°~495°~405°)	Medium waving 5 times	3.2s	189-191
75	J2~D2~J2 (495°~405°~495°)	Medium waving 5 times	3.2s	192-193
76	R1~J1~R1 (225°~135°~225°)	Medium waving 5 times	3.2s	194-196
77	J1~R1~J1 (135°~225°~135°)	Medium waving 5 times	3.2s	197-198
78	A2-G2-A2 (360°~450°~360°)	Slow waving 3 times	4.80s	199-201
79	G2-A2-G2 (450°~360°~450°)	Slow waving 3 times	4.80s	202-203
80	A2-S1-A2 (360°~270°~360°)	Slow waving 3 times	4.80s	204-206
81	S1-A2-S1 (270°~360°~270°)	Slow waving 3 times	4.80s	207-209
82	S1-M1-S1 (270°~180°~270°)	Slow waving 3 times	4.80s	210-211
83	M1-S1-M1 (180°~270°~180°)	Slow waving 3 times	4.80s	212-214
84	G2-M2-G2 (450°~540°~450°)	Slow waving 3 times	4.80s	215-216
85	M2-G2-M2 (540°~450°~540°)	Slow waving 3 times	4.80s	217-219
86	V1~D2~V1 (315°~405°~315°)	Slow waving 3 times	4.80s	220-221
87	D2~V1~D2 (405°~315°~405°)	Slow waving 3 times	4.80s	222-224
88	V1~R1~V1 (315°~225°~315°)	Slow waving 3 times	4.80s	225-226
89	R1~V1~R1 (225°~315°~225°)	Slow waving 3 times	4.80s	227-229
90	D2~J2~D2 (405°~495°~405°)	Slow waving 3 times	4.80s	230-232
91	J2~D2~J2 (495°~405°~495°)	Slow waving 3 times	4.80s	233-234
92	R1~J1~R1 (225°~135°~225°)	Slow waving 3 times	4.80s	235-237
93	J1~R1~J1 (135°~225°~135°)	Slow waving 3 times	4.80s	238-239
94	0°	Fixed angle firing	Depends on CH3	240-255

DMX control example 1: firing sequence No. 42

1. Set output nozzle straight up
CH1 = 128, CH2 = 0, CH3 = 0, CH4 = 0, CH5 = 0, CH6 = 128
2. Set preset Sequence No. 42
CH1 = 128, CH2 = 0, CH3 = 0, CH4 = 0, CH5 = 108, CH6 = 128
3. Firing, put CH3 to 255 and hold for at least 1s. SPARKULAR WHEEL will finish sequence 42 automatically.
CH1 = 128, CH2 = 0, CH3 = 255, CH4 = 0, CH5 = 108, CH6 = 128

DMX control example 2: firing sequence No. 2, firing time 10s

1. Set output nozzle straight up
CH1 = 128, CH2 = 0, CH3 = 0, CH4 = 0, CH5 = 0, CH6 = 128
2. Set preset Sequence No. 2
CH1 = 128, CH2 = 0, CH3 = 0, CH4 = 0, CH5 = 6, CH6 = 128
3. Firing, put CH3 to 255 and hold for 10s
CH1 = 128, CH2 = 0, CH3 = 255, CH4 = 0, CH5 = 6, CH6 = 128
Keep 10s.
4. Firing OFF
CH1 = 128, CH2 = 0, CH3 = 0, CH4 = 0, CH5 = 0, CH6 = 128

DMX control example 3: firing sequence No. 10

1. Set output nozzle straight up
CH1 = 128, CH2 = 0, CH3 = 0, CH4 = 0, CH5 = 0, CH6 = 128
2. Set preset Sequence No. 10
CH1 = 128, CH2 = 0, CH3 = 0, CH4 = 0, CH5 = 26, CH6 = 128
3. Firing, put CH3 to 255 and hold for 30s
CH1 = 128, CH2 = 0, CH3 = 255, CH4 = 0, CH5 = 26, CH6 = 128
Fast cycling for 30s.
4. Firing, put CH2 to 128 and hold for 30s
CH1 = 128, CH2 = 128, CH3 = 255, CH4 = 0, CH5 = 26, CH6 = 128
Medium cycling for 30s.
5. Firing OFF
CH1 = 128, CH2 = 0, CH3 = 0, CH4 = 0, CH5 = 0, CH6 = 128

8. Wireless Control

SPARKULAR WHEEL can be firing wirelessly by FXmote. When use FXmote for remote control, please disconnect DMX cable connection, set machine to Wireless Control to ON status in advanced menu. Select "DEVICE" SPARKULAR on FXmore (please refer to FXmote manual), Match machine with FXmote by Press "SET" on FXmote when machine at Wireless Control interface.

FXmote is not standard configuration, if you need to order please contact SHOWVEN sales.

FXmote will firing the exact sequence that you set in the main menu.



Δ Operation Guide

1. Install SPARKULAR® WHEEL

a) To meet different application scenario, we designed mutli installation interface for SPARKULAR® WHEEL as show below.

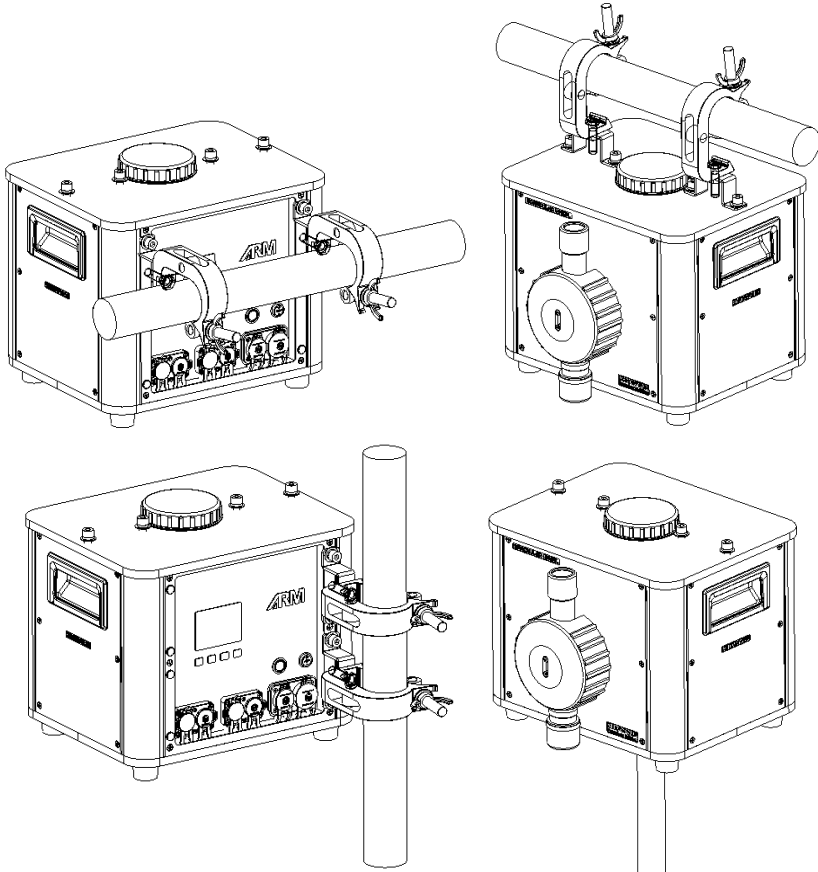

- b) Make sure the machine is securely installed to avoid falling, make sure to install extra safety rope for each machine.
- c) Check carefully the output nozzle of each machine, make sure the output nozzle is in good shape and there is no powder aggregate.

2. Fill SPARKULAR® WHEEL

- a) Open powder bags and fill the feeding hopper.
- b) Choose correct consumable according to the hanging height and safety distance..
- c) Please be noted that there may sparks or remains fall to the ground. Make sure no flammable material on ground in the safety zone.
- d) Make sure the lid of hopper is locked tight after filling.

SAFETY NOTICE: Accidentally burning of consumable HC8200 in the hopper can only use sands to extinguish.

3. Connect Power / DMX cable

- a) Connect a power cable to the POWER IN socket of SPARKULAR® WHEEL. Connect the other end of power cable to the power source. Make sure power supply in consistent with the rated voltage of the equipment, and the socket must well grounded.
- b) If connect machine in sequence, please connect a power link cable to the POWER OUT of previous machine, connect the other end of the power link cable to POWER IN of the next machine.
- c) The SPARKULAR® WHEEL power supply cable maximum allowed cascade is 6 units (220V version) / 3pcs (110V version). Do not connect exceed units to a single electrical circuit.
- d) Power ON all SPARKULAR® WHEEL.
- e) Assign DMX address for each unit of SPARKULAR® WHEEL. If use SHOWVEN FXcommander to control the machine please allocate a unique DMX address for each unit of machine. If use FXmote to control SPARKULAR® WHEEL wirelessly, please set machine to wireless ON status and match machine with FXmote. For DMX cable control please execute below operations (f to h).
- f) Connect a DMX cable to the DMX IN socket of first unit of SPARKULAR® WHEEL, connect the male connector end of DMX cable to your DMX controller (FXcommander, FXbutton, light console etc).
- g) Connect a DMX cable to the DMX OUT of previous machine, and the other end of to the DMX IN of next machine. Connect all devices in series in this way.
- h) Plug in a DMX terminator into the DMX OUT in last unit of machine to improve signal reliability. Signal amplifier is required for long distance (>200m) DMX signal transmission (SHOWVEN DMX splitter 8 with bidirectional signal transmission, thus can get signal feedback from device).

4. Activate SPARKULAR® WHEEL by swipe RFID card

- a) Swipe an V2.0 RFID card. SPARKULAR® WHEEL shows time remain if read successfully. SPARKULAR® WHEEL report E4 when remaining time is less than 10 minutes.
- b) Please note each RFID card come with 200g package HC8200 can increase single machine 20min working time, the maximum recharge time for SPARKULAR® WHEEL is 30min, when time remain reached 30min, it can't recharge anymore RFID card.

5. Programming and Firing

- a) Programming SPARKULAR® WHEEL, set the firing sequences etc.
- b) Heating up, it takes few minutes, it varies according to the voltage and environment temperature.
- c) Make sure the prescribed safety zone of related firing sequences are clear.
- d) Suggest to clear material for SPARKULAR® WHEEL before firing.
- e) Firing. In order to prevent overheat in the heating chamber and protect machine, the maximum continuous firing time for SPARKULAR® WHEEL is 180s.
- f) The operator should always have a clear view of the device, so that he/she can stop the show immediately when there is danger.
- g) Running preset sequence No.1 to clear material for SPARKULAR® WHEEL after show, clear material will remove the remaining particles from heating chamber.

6. Turn Off and clean up

- a) Power off SPARKULAR® WHEEL, allow SPARKULAR® WHEEL to cool down.
- b) Disconnect all POWER and DMX cables.
- c) Empty the remaining HC8200 in hopper, and store the remaining HC8200 in a dry sealed bottle for next time use. Never touch the output nozzle of SPARKULAR® WHEEL when empty the hopper. DANGER OF GET BURNT!
- d) Operators can use handheld vacuum cleaner to empty the feeding hopper. Do make sure the machine was cool down when clean it. Do NOT use high-power vacuum cleaners to avoid hot consumables being sucked into the vacuum cleaner from the heating chamber and cause fire.
- e) Clean the surroundings to remove powder residues.

Δ Maintenance

- a) Empty the feeding hopper before shipment of machine.
- b) Empty the feeding hopper if long time not use, for high humidity environment we suggest to empty feeding hopper after each show.
- c) Clear material both before and after the show.

Δ **Warranty Instructions**

- \ Sincere thanks for your choosing our products, you will receive quality service from us
- \ The product warranty period is one year. If there are any quality problems within 7 days after shipping out from our factory, we can exchange a brand new same model machine for you
- \ We will offer free of charge maintenance service for machines which with hardware malfunction (except for the instrument damage caused by human factors) in warranty period. Please don't repair machine without factory permission

Below situations NOT included in warranty service:

- \ Damage caused by use other type of consumable which is not originally from SHOWVEN®.
- \ Damage caused by improper transportation, usage, management, and maintenance, or damage caused by human factors;
- \ Disassemble, modify or repair products without permission;
- \ Damage caused by external reasons (lightning strike, power supply etc.)
- \ Damage caused by improper installation or use;

For product damage not included in warranty range, we can provide paid service.

Invoice is necessary when applying for maintenance service from SHOWVEN®.

SHOWVEN[®]



Showven Technologies Co., Ltd.

Tel: +86-731-83833068

Web: www.showven.cn E-mail: info@showven.cn

Add: No.1 Tengda Road, Liuyang Economic & Technical Development Zone, Changsha, Hunan,
410300, P.R.China