

uFlamer Gasboom



uFlamer Gasboom is the safest gas flamer ever on the market, with a series of safety features including 0.1s super sensitive flame monitoring, cascadable power cut-off E-stop connector, dual high voltage electron igniter, patented "SFT" technology, safety lock, dual magnetic valves, shut-off valve, ARM warning light etc. With 5 types of nozzles optional, 2/4 built-in gas cartridges positions, flame effect height from 2 to 8m ensure versatile applications for both indoor and outdoor events.

Features

- \ Patented "SFT" technology allows Gasboom with stronger burst and no flame tails after firing even in low temperature environment.
- \ Super sensitive flame monitoring ensures that the fuel supply is switched off if the flame does not ignite after as short as a 0.1s firing duration
- \ Cascadable power cut-off E-stop connector, all flammers can be controlled with a single E-stopper box.
- \ Dual high voltage electron igniter ensure successful ignition
- \ Dual magnetic valves installed in series for double safety
- \ Individual shut-off valve for each canister
- \ Built-in battery design
- \ 2 / 4 (optional) built-in gas cartridges positions
- \ 5 types of nozzles optional, 2-8m effects
- \ Stainless steel housing, reliable and durable
- \ Waterproof design, can be used in heavy rain
- \ Safety lock with switchable test mode, safer for service and testing
- \ Tilt protection, the tilt sensor will be activated when machine slant Over 45°.

Specifications

Dimension

320 x 310 x 325 mm

Weight

13 kg

Input and Power

100-240VAC, 50/60 Hz

200W

Housing Material

304 stainless steel

Effect Direction

Vertical

Flame Height

2-8m (canister QTY, nozzle size etc)

E-Stop Interface

Yes, can be connected in series

Dual Magnetic Valves

Yes, connect in series

High Sensitive Flame Monitoring

Yes, sensitivity up to 0.1s

Interface

NEUTRIK POWERCON TRUE1 IN/OUT

Waterproof 3-pin and 5-pin XLR IN/OUT

Control

DMX 512, 9-60V voltage input

Wireless, with Wireless DMX Receiver (5-PIN DMX IN with DC5V power supply)

Ignition

High Voltage Electron Ignition * 2

Built-in Battery Design

Yes, 4*18650 Lithium cells

Waterproof Level

Can be used in heavy rain

Firing Duration

0.1-10s

Fuel

LPG propane or butane gas, gas cartridges bottle, aerosol cartridges

Cartridge Holder

Twin cartridge holder with 2 shut-off valves and 2 non-return valves

Quadruple cartridge holder with 4 shut-off valves and 4 non-return valves (optional)

Micro Filter

Yes, installed between shut-off and non-return valves

Effects



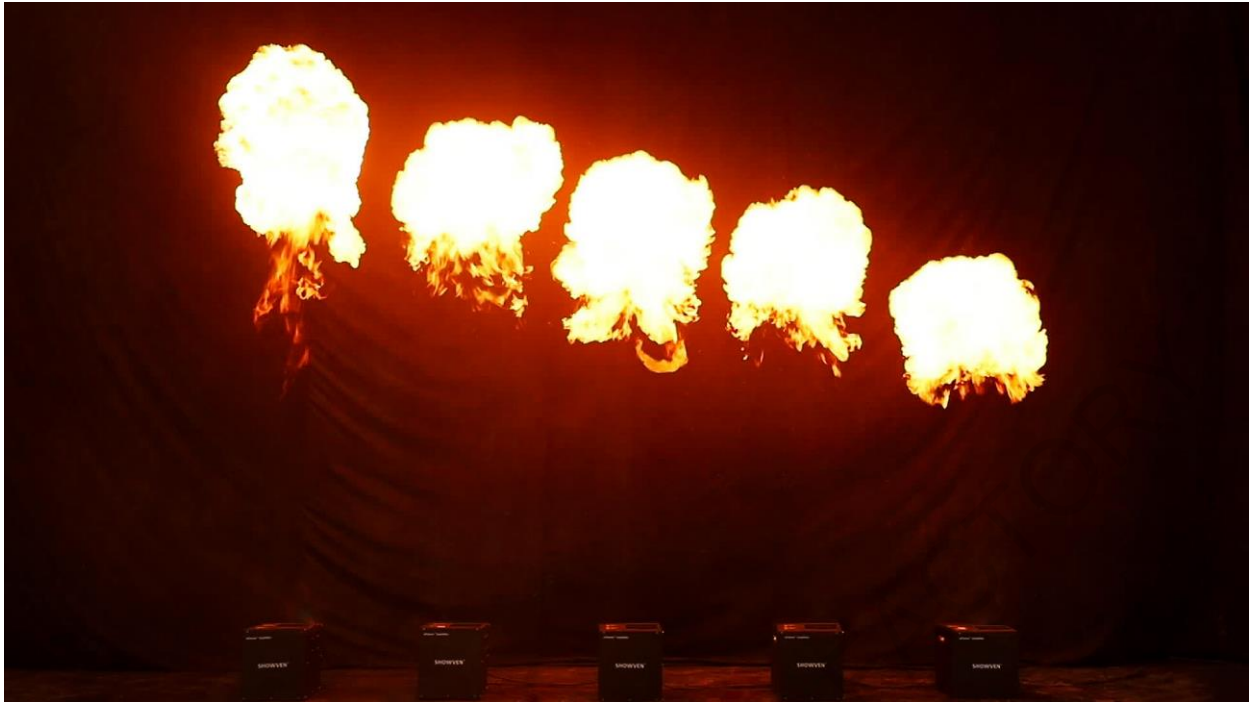

DOCUMENT PREMIUM

U-FLAMER GASBOOM FAQ

Gas canister/cartridge suggested for Gasboom.

Cartridge holder for 2 support cartridge with outer diameter is less than or equal to $\phi 110\text{mm}$, and the height is less than 275mm.

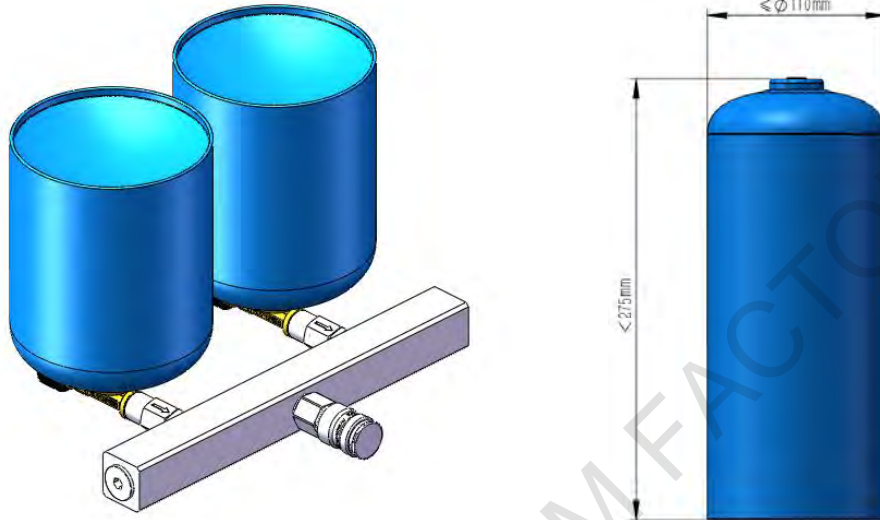

Cartridge holder for 4 support cartridge with outer diameter is less than or equal to $\phi 66\text{mm}$, and the height is less than 275mm.

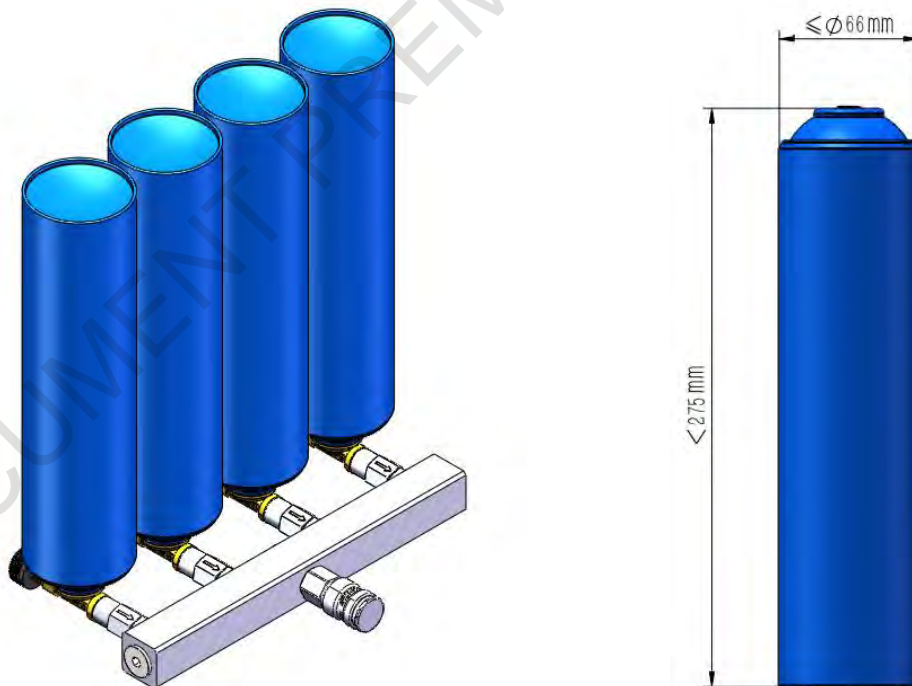

Safety Distance for Gasboom.

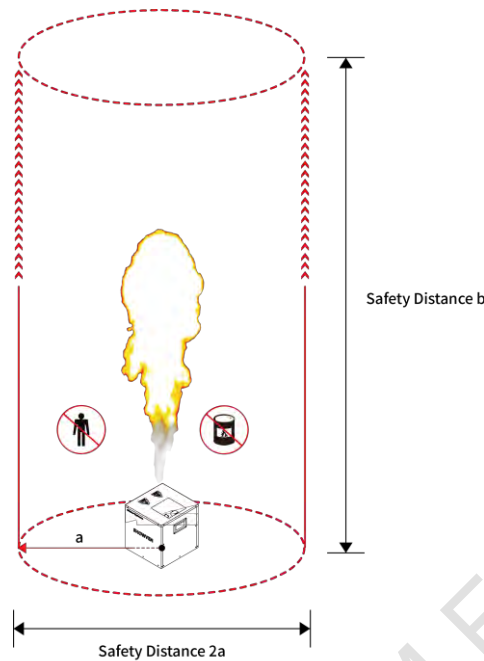

The uFlamer Gasboom safety isolation zone (show as above) is a cylindrical three-dimensional space with safety radius around machine (a) and safety distance at firing direction (b). For safety distance at firing direction equals to maximum firing height+2m. No person and flammable materials are allowed to stay inside the safety isolation zone when flamer was armed. Unauthorized persons and objects are strictly prohibited from entering.

NOTE: For angled installation, the safety distance both around machine and firing direction should shift accordingly.

Gasboom effect height and safety distance

Effect height test result we get is based on two 450g gas cartridges as show in below picture, and firing duration is 0.2s. Below effect height and safety distance are for reference, if necessary, please expand the safety distance according to the actual situation.



Nozzle G16, G20 and G25

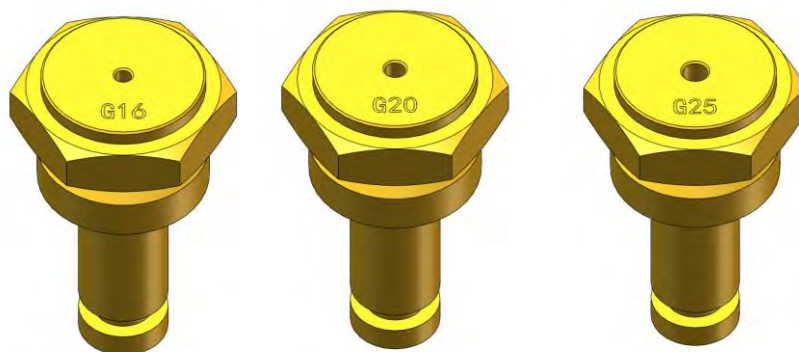

Nozzle Type	Temperature	-10~0°C	0~10°C	10~30°C	30~40°C
G16	Effect Height (m)	1.5~2.5	2.5~3.0	3.0~3.5	2.5~3.0
	Safety Distance a (m)	2	2.5	2.5	2.5
	Safety Distance b (m)	4.5	5.0	5.5	5.0
G20	Effect Height (m)	2.0~3.0	3.0~3.5	3.5~4.0	3.0~3.5
	Safety Distance a (m)	2.5	2.5	2.5	2.5
	Safety Distance b (m)	5.0	5.5	6.0	5.5
G25	Effect Height (m)	2.5~3.5	3.5~4.0	4.0~4.5	3.5~4.0
	Safety Distance a (m)	2.5	2.5	3.0	2.5
	Safety Distance b (m)	5.5	6.0	6.5	6.0

Nozzle GA

Nozzle GA can be used with gas cartridge, and it is only suitable for 10°C~40°C.

It is forbidden to use Nozzle GA with gas cartridge when temperature is lower than 10 °C.

Nozzle Type	Temperature	10~15°C	15~30°C	30~40°C
GA	Effect Height (m)	4.5~7.0	5.5~8.0	4.5~7.0
	Safety Distance a (m)	4.0	4.0	4.0
	Safety Distance b (m)	9.0	10.0	9.0



Fuel consumption

Below testing result is based on two 450g gas cartridges as show in above picture, and firing duration is 0.2s, environment temperature is 30°C.

Nozzle type	G16	G20	G25	GA
0.2s flame ball quantity	≈ 350 shots	≈ 270 shots	≈ 200 shots	≈ 110 shots