

# SPARKULAR PRO USER MANUAL

V1.0

SHOWVEN®



Showven Technologies Co.,Ltd.

# SPARKULAR PRO USER MANUAL

- ★ Please read this manual carefully before operating this product.
- ★ Warranty card attached in the manual, please keep it well.

## Safety Considerations

- » Unauthorized repair are prohibited, it may cause serious incident.
- » Do NOT soak the machine in water.
- » Make sure lid of feeding hopper are well covered when use SPARKULAR PRO. Accidentally burning of Composite Ti can only use sands to extinguish. Composite Ti should keep away from moisture and stored in a dry sealed environment.
- » Keep audience, animals or flammable objects at a minimum distance of 3m from SPARKULAR PRO. Make sure sparks shoot out from SPARKULAR PRO can NOT touch any objects in the air.
- » Clear material is necessary both before and after the show. Please check nozzle of SPARKULAR PRO after each show, if there are consumable agglomerated in the nozzle, please clear it with screwdriver, otherwise it will affect the spark effects and even damage the machine.
- » Maximum cascade of SPARKULAR PRO is 5 units (110V version no more than 3units) with one standard power cable. Otherwise it may damage the machine and even cause fire.
- » For better heat dissipation, block the air intake and air outlet is prohibited.
- » Cover of nozzle of SPARKULAR PRO is prohibited. Please check the nozzle before each show ensure the nozzle not blocked by foreign body.
- » Never touch the sparks which shooting out from the nozzle. Never touch the nozzle of SPARKULAR PRO, danger of getting burnt.
- » Ensure that children, animals and unauthorized persons don't have access to the SPARKULAR PRO!
- » please be noted that there may sparks or remains fall to the ground when use HC8200 LARGE and LARGE I .

## Features

SPARKULAR PRO is derived from SHOWVEN original SPARKULAR technology platform for outdoor installations and professional outdoor show market. IP55 rated weatherproof enclosure design allows SPARKULAR PRO works even in heavy rainfall. 1200g huge hopper design ensure long effects time after each filling up. It is an ideal choice for outdoor events, theme parks, projects installations etc.

# Technical Specifications

Product name	SPARKULAR PRO
Model	BT71/BT72
Dimension	315x290x285mm
Weight	16.5Kg
Input	AC 220VAC-240VAC,50/60HZ; 600W Max.cascade: 5PCS; AC 100VAC-120VAC,50/60HZ; 700W Max.cascade: 3PCS;
Work Temp.	-20°C~50°C
Effect height	HC8200 LARGE / HC8200 LARGE I : 5~5.5m
Height adjustable	Yes
Effect direction	Straight up
Hopper capacity	1200g
Height adjustable	Yes
HC8200 consumption rate	20g/min
Interface	NEUTRIK POWERCON TRUE1, 3-pin waterproof DMX connectors
Control	DMX

## Operation Panel

### LED display area:



**READY:** Flashing means heating up, about 5min. Turns from flashing into long on, indicates that the machine is ready to work.

**DMX:** Flashing shows that DMX signal is connected, light OFF means there is no DMX signal

**FAULT:** Light ON when error occurs

**HEAT:** Light ON when system is heating up

### Control Button Area:

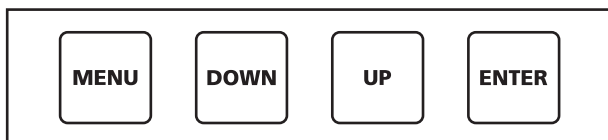

**MENU:** switch through setup menu. Press 3s switch to advanced interface

**DOWN:** parameter down

**UP:** parameter up

**ENTER:** confirm and save parameters

## RFID area:

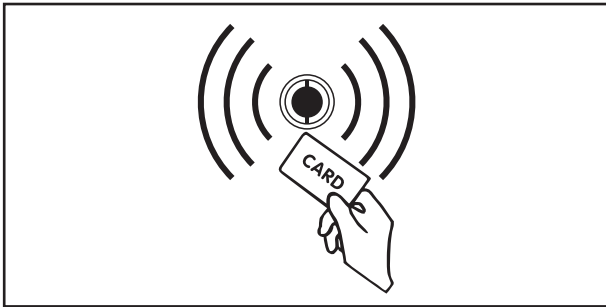

RFID card comes together with HC8200. It is a safety design, allows machine to identify the parameter and types of consumable.

Please note that granules RFID card can increase the single machine specific working time. The card is disposable, can only use once.

## Interface

### Main interface:

<b>DMX Address</b>	<b>1</b>
<b>210 ■ ■</b>	

First line: shows DMX address

Second Line: shows inner temp. and temp. bar, as well as error info if available

### Error information:

Error Informations	Explanation
E0 System IC	Systematic error
E2 Temp. Sensor	Temperature sensor is not connected or damage
E3 P Temp. Over	Chassis over-temperature
E4 Time Remain	Activated time for machine is not enough, need to swip RFID card
E5 K Temp. Over	Inner core over-temperature
E6 Heat Fail	Heating Fail

## Setting Menu:

Press "MENU" switch through setup menu.

Options	Range	Explanation
Set DMX Address	1-512	Set DMX address If controlled by Host Controller, please set DMX address as 1, 3, 5, 7,...2n-1, otherwise it may leads to signal interference
Fountain Height	1-10	Manual firing height setup, for test only
Manual Heat	ON/OFF	Auto heating up ON/OFF
Manual Fountain	ON/OFF	Manual firing, for test only
Auto Clear Delay	0.1-0.9s	Auto clear material time after each firing

## Advanced Menu:

Press "MENU" 3 seconds to enter the advanced setup interface, press MENU key to enter different options wait 3 seconds to return to the main interface.

Options	Range	Explanation
Set Temperature	580-620	Default is 580. Please don't change default value without engineer's suggestion from SHOWVEN.
LCD Backlight	ON/OFF	LCD screen backlight ON/OFF
Density	70-100	Sparks density
Mode Selection	Factory Mode User Mode	Factory mode is for engineer only. When in Factory mode machine can't controlled by DMX console/host controller
Motor Protect	ON/OFF	Motor protect function, default setting is Off
Standby Switch	ON/OFF	When ON, the machine can firing only when heating up was finished

## **SPARKULAR PRO occupy 2 channels when use DMX.**

<b>First channel</b>	<b>Function</b>
0-15	Fountain OFF
16-39	Fountain Height 1
40-63	Fountain Height 2
64-87	Fountain Height 3
88-111	Fountain Height 4
112-135	Fountain Height 5
136-159	Fountain Height 6
160-183	Fountain Height 7
184-207	Fountain Height 8
208-231	Fountain Height 9
232-255	Fountain Height 10
<b>Second channel</b>	<b>Function</b>
60-80	Clear Material (perform after each show)
20-40	Emergency Stop
0-10	Pre-heat OFF (disabled when auto-heat ON)
240-255	Pre-heat ON (disabled when auto-heat ON)

Please follow belowing rules to set DMX address when use SHOWVEN Host Controller, otherwise it may leads to signal interference.

Sparkular No.	1	2	3	4	5	6	7	8	9	10	11	12	13	14	15	16	17	18
DMX Address	1	3	5	7	9	11	13	15	17	19	21	23	25	27	29	31	33	35

## Fixed Installation

Do not soak the machine in water, install on holder if necessary. Install in below way:

Unload the 4 foot screw, install SPARKULAR PRO via 4 M10 hole.

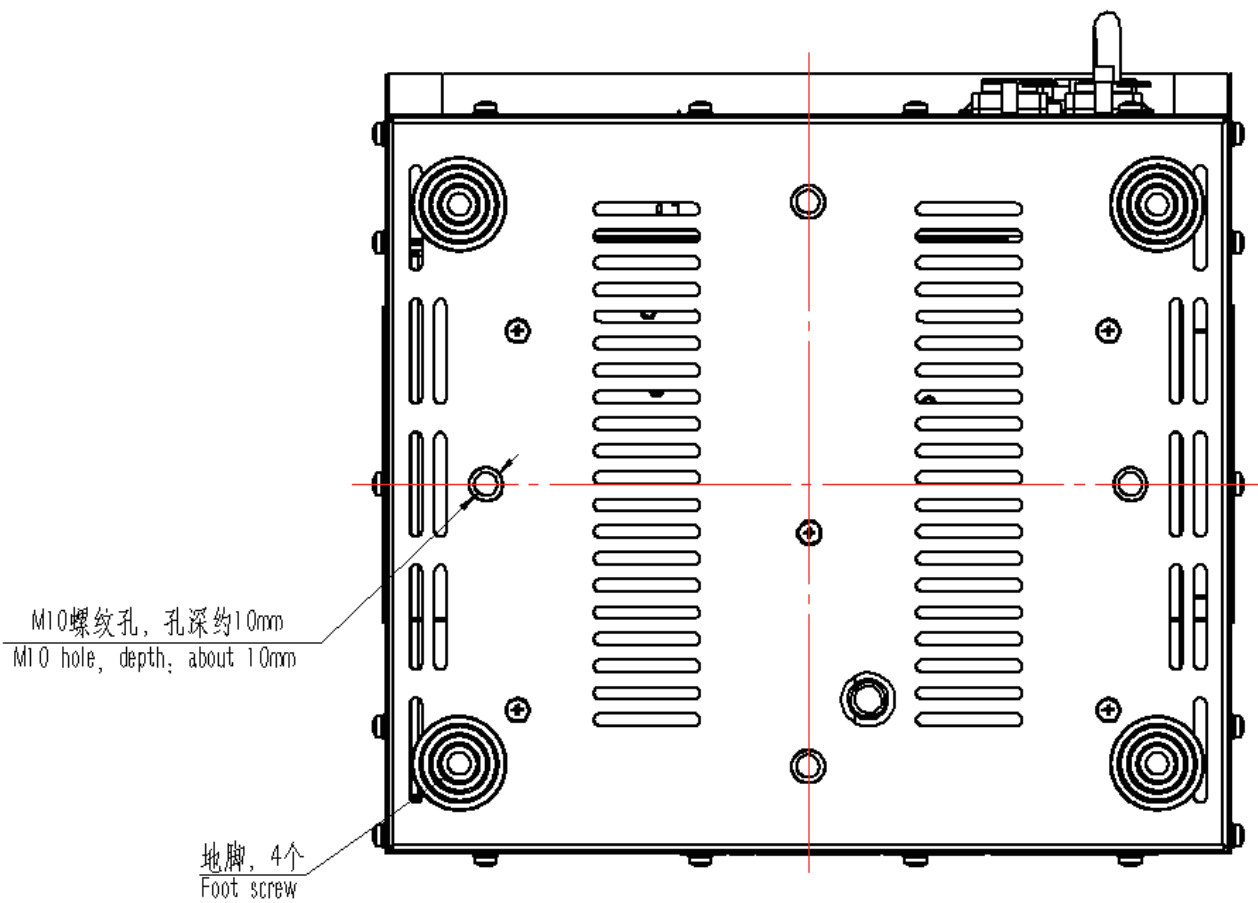

# Warranty Instructions

- ▲ Sincere thanks for your choosing SPARKULAR PRO, you will receive quality service from us.
- ▲ The product warranty period is one year. If there are any quality problems within 7 days after shipping out from our factory, we can exchange a brand new same model machine for you.
- ▲ We will offer free of charge maintenance service for machines which with hardware malfunction (except for the instrument damage caused by human factors) in warranty period. Please don't repair machine without factory permission.

★ **Below situations NOT included in warranty service:**

1. Damage caused by improper transportation, usage, management, and maintenance, or damage caused by human factors;
2. Disassemble, modify or repair products without Showven's permission;
3. Damage caused by external reasons (lightning strike, power supply etc);
4. Damage caused by improper installation or use;

For product damage not included in warranty range, we can provide paid service.

★ **Invoice and warranty card are necessary when applying for maintenance service from SHOWVEN.**

## Warranty Card

Product Name:		Serial No.	
Purchase Date:			
Tel:			
Address:			
Problem Feedback:			
Actual Problem:			
Maintenance Detail:			
Service Engineer:		Service Date:	





# SHOWVEN<sup>®</sup>



## **Showven Technologies Co., Ltd.**

Add: Building B1, Changsha E Center No.18, Xiangtai Road, Liuyang Economic Development Zone, Changsha City, 410300, Hunan Province, P.R.China.

Tel: +86-731-83833068

Web: [www.showven.cn](http://www.showven.cn)

E-mail: [info@showven.cn](mailto:info@showven.cn)